

**Model: C1250 D5A**  
**Frequency: 50**  
**FuelType: Diesel**

**»Generator set data sheet**

**1250kVA Standby**



**Our energy working for you.™**

<b>Fuel consumption</b>	<b>Standby</b>				<b>Prime</b>			
	<b>kW (kVA)</b>				<b>kW (kVA)</b>			
Ratings	1000(1250)				900(1125)			
Load	<b>1/4</b>	<b>1/2</b>	<b>3/4</b>	<b>Full</b>	<b>1/4</b>	<b>1/2</b>	<b>3/4</b>	<b>Full</b>
USgph	20.9	36.2	51.8	67.6	N.A.	N.A.	N.A.	N.A.
L/hr	79	137	196	256	N.A.	N.A.	N.A.	N.A.

<b>Engine</b>	<b>Standby rating</b>	<b>Prime rating</b>
Engine manufacturer	Cummins	
Engine model	KTA38G9	
Configuration	4-Cycle; 60° Vee; 12-Cylinder Diesel	
Aspiration	Turbocharged and Aftercooled	
Gross engine power output, kWm	1089	N.A.
BMEP at set rated load, kPa	2296	N.A.
Bore, mm	159	
Stroke, mm	159	
Rated speed, rpm	1500	
Piston speed, m/s	7.9	
Compression ratio	13.9:1	
Lube oil capacity, L	114	
Over speed limit, rpm	1800±50	
Regenerative power, kWm	86	
Governor type	Electronic	
Starting voltage	24VoltsDC	

<b>Fuel flow</b>	
Maximum fuel flow, L/hr	428
Maximum fuel inlet restriction, mm Hg	203
Maximum fuel inlet temperature(°C)	60

<b>Air</b>	
Combustion air, m <sup>3</sup> /min	78.5
Maximum air cleaner restriction, mm H <sub>2</sub> O	635

<b>Exhaust</b>	<b>Standby rating</b>	<b>Prime rating</b>
Exhaust gas flow at set rated load, m <sup>3</sup> /min	212.4	N.A.
Exhaust gas temperature, °C	529	N.A.
Maximum exhaust back pressure, mm Hg	76	

<b>Standard set-mounted radiator cooling</b>		
Ambient design, °C	40	
Fan load, KW <sub>m</sub>	24	
Coolant capacity (with radiator), L	336	
Cooling system air flow, m <sup>3</sup> /min@12.7 mmH <sub>2</sub> O	1128	
Total heat rejection, BTU/min	37960	N.A.
Maximum cooling air flow static restriction mmH <sub>2</sub> O	12.7	

<b>Weights*</b>	<b>Open</b>	<b>Enclosed</b>
Unit dry weight kgs	8179	N.A.
Unit wet weight kgs	8569	N.A.

\* Weights represent a set with standard features. See outline drawing for weights of other configurations

<b>Dimensions</b>	<b>Length "A"</b>	<b>Width "B"</b>	<b>Height "C"</b>
Standard open set dimensions, mm	4722	1785	2241
Enclosed set standard dimensions, mm	20'container	-	-

## Genset outline

### Open set

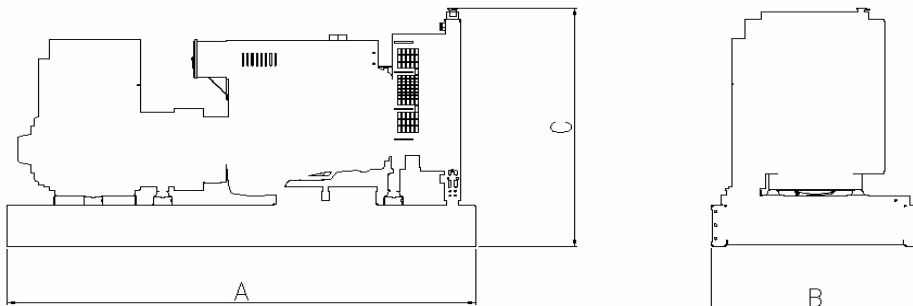

### Enclosed set

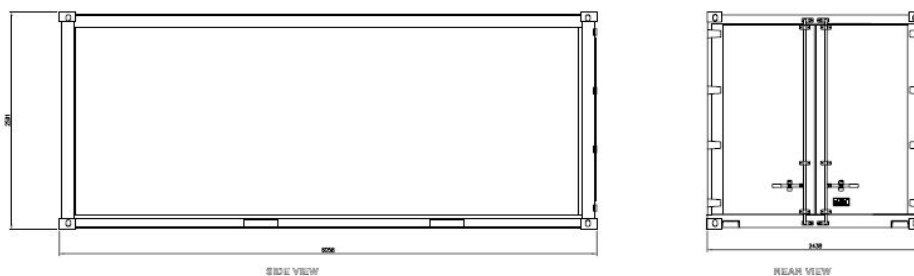

Outlines are for illustrative purposes only. Please refer to the genset outline drawing for an exact representation of this model.

**Our energy working for you.™**

[www.cumminspower.com](http://www.cumminspower.com)

©2007 Cummins Power Generation Inc. All rights reserved. Cummins Power Generation and Cummins are registered trademarks of Cummins Inc.™ "Our energy working for you." is a trade mark of Cummins Power Generation. EA\_S\_CC\_39 V1\_1406



## Alternator data

Feature code	Connection <sup>1</sup>	Temp rise	Duty <sup>2</sup>	Alternator	Voltage
-	Wye, 3 Phase	125/105	S/P	P7A	380-415V

## Ratings definitions

Standby:	Limited Time Running:	Prime (unlimited running time):	Base Load (Continuous):
Applicable for supplying power to varying electrical load for the duration of power interruption of a reliable utility source. Emergency Standby Power (ESP) is in accordance with ISO 8528. Fuel Stop power in accordance with ISO 3046, AS 2789, DIN 6271 and BS 5514.	Applicable for supplying power to a constant electrical load for limited hours. Limited Time Running Power is in accordance with ISO 8528.	Applicable for supplying power to varying electrical load for unlimited hours. Prime Power is in accordance with ISO 8528. Ten percent overload capability is available in accordance with ISO 3046, AS 2789, DIN 6271 and BS 5514.	Applicable for supplying power continuously to a constant electrical load for unlimited hours. Continuous power in accordance with ISO 8528, ISO 3046, AS 2789, DIN 6271 and BS 5514.

### Notes:

- Limited single phase capability is available from some three phases rated configurations. To obtain single phase rating, multiply the three phase kW rating by the single phase factor. All single phase ratings are at unity power factor.
- Standby (S) and Prime (P) ratings.

## Formulas for calculating full load currents:

### Three phase output

$$\frac{\text{kW} \times 1000}{\text{Voltage} \times 1.732 \times 0.8}$$

### Single phase output

$$\frac{\text{kW} \times 1000}{\text{Voltage}}$$

**See your distributor for more information.**

### Cummins Power Generation

#### Europe, CIS, Middle East and Africa

Manston Park Columbus Ave  
Manston, Ramsgate  
Kent CT12 2BF United Kingdom  
Phone 44 1843 255000  
Fax 44 1843 255902

#### Asia Pacific

10 Toh Guan Road #07-01  
TT International Tradepark  
Singapore 608838  
Phone 65 6417 2388  
Fax 65 6417 2399

#### East Asia

2 Rongchang East Street  
Beijing Economic-Technological  
Development Area  
Beijing 1000176 P.R China  
Phone 86 10 5902 3000  
Fax 86 10 5902 3199

**Our energy working for you.™**

[www.cumminspower.com](http://www.cumminspower.com)

# PowerCommand® 3.3 control system



## > Specification sheet

Our energy working for you.™



## Power Generation

### Control system description

The PowerCommand® control system is a microprocessor-based genset monitoring, metering and control system designed to meet the demands of today's engine driven gensets. The integration of all control functions into a single control system provides enhanced reliability and performance, compared to conventional genset control systems. These control systems have been designed and tested to meet the harsh environment in which gensets are typically applied.

### Features

- 320 x 240 pixels graphic LED backlight LCD.
- Multiple language support.
- AmpSentry™ protection - for true alternator overcurrent protection.
- Digital Power Transfer Control (AMF) provides load transfer operation in open transition, closed transition, or soft (ramping) transfer modes.
- Extended Paralleling (Peak Shave/Base Load) regulates the genset real and reactive power output while paralleled to the utility. Power can be regulated at either the genset or utility bus monitoring point.
- Digital frequency synchronization and voltage matching.
- Isochronous Load Share
- Droop KW and KVAR Control
- Real time clock for fault and event time stamping.
- Exerciser clock and time of day start/stop initiate a test with or without load, or a Base Load or Peak Shave session.
- Digital voltage regulation. Three phase full wave FET type regulator compatible with either shunt or PMG systems.
- Digital engine speed governing (where applicable)
- Generator set monitoring and protection.
- Utility/AC Bus metering and protection
- 12 and 24 V DC battery operation.
- Modbus® interface for interconnecting to customer equipment.
- Warranty and service. Backed by a comprehensive warranty and worldwide distributor service network.
- Certifications - Suitable for use on gensets that are designed, manufactured, tested and certified to relevant UL, NFPA, ISO, IEC, Mil Std. and CE standards.

# PowerCommand digital genset control PCC 3300



## Description

The PowerCommand genset control is suitable for use on a wide range of diesel and lean burn natural gas gensets in paralleling applications. The PowerCommand control is compatible with shunt or PMG excitation style. It is suitable for use with reconnectable or non-reconnectable generators, and it can be configured for any frequency, voltage and power connection from 120-600 VAC line-to-line, 601-45,000 VAC with external PT.

Power for this control system is derived from the genset starting batteries. The control functions over a voltage range from 8 VDC to 30 VDC.

## Features

- 12 and 24 VDC battery operation.
- Digital voltage regulation - Three phase full wave FET type regulator compatible with either shunt or PMG systems. Sensing is three phase.
- Digital engine speed governing (where applicable) – Provides isochronous frequency regulation.
- Full authority engine communications (where applicable) - Provides communication and control with the Engine Control Module (ECM).
- AmpSentry™ protection - for true alternator overcurrent protection.
- Genset monitoring - Monitors status of all critical engine and alternator functions.
- Digital genset metering (AC and DC).
- Genset battery monitoring system to sense and warn against a weak battery condition.
- Configurable for single or three phase AC metering.
- Engine starting - Includes relay drivers for starter, fuel shut off (FSO), glow plug/spark ignition power and switch B+ applications.
- Genset protection – Protects engine and alternator.
- Real time clock for fault and event time stamping.

- Exerciser clock and time of day start/stop initiate a test with or without load, or a Base Load or Peak Shave session.
- Digital Power Transfer Control (AMF) provides load transfer operation in open transition, closed transition, or soft (ramping) transfer modes.
- Extended Paralleling (Peak Shave/Base Load) regulates the genset real and reactive power output while paralleled to the utility. Power can be regulated at either the genset or utility bus monitoring point.
- Digital frequency synchronization and voltage matching.
- Isochronous Load Share
- Droop KW and KVAR Control
- Sync Check – The sync check function has adjustments for phase angle window, voltage window, frequency window and time delay.
- Utility/AC Bus metering and protection
- Advanced serviceability – using InPower™, a PC-based software service tool.
- Environmental protection – The control system is designed for reliable operation in harsh environments. The main control board is a fully encapsulated module that is protected from the elements.
- ModBus interface for interconnecting to customer equipment.
- Configurable inputs and outputs – Four discrete inputs and four dry contact relay outputs.
- Warranty and service – Backed by a comprehensive warranty and worldwide distributor service network.
- Certifications – Suitable for use on gensets that are designed, manufactured, tested and certified to relevant UL, NFPA, ISO, IEC, Mil Std. and CE standards.

## Base control functions

### HMI capability

Options – Local and remote HMI options

Operator adjustments – The HMI includes provisions for many set up and adjustment functions.

Genset hardware data – Access to the control and software part number, genset rating in KVA and genset model number is provided from the HMI or InPower.

Data logs – Includes engine run time, controller on time, number of start attempts, total kilowatt hours, and load profile. (Control logs data indicating the operating hours at percent of rated kW load, in 5% increments. The data is presented on the operation panel based on total operating hours on the generator.)

Fault history – Provides a record of the most recent fault conditions with control date and time stamp. Up to 32 events are stored in the control non-volatile memory.

Alternator data

Our energy working for you.™

[www.cumminspower.com](http://www.cumminspower.com)

©2010 Cummins Power Generation Inc. All rights reserved. Cummins Power Generation and Cummins are registered trademarks of Cummins Inc. PowerCommand, AmpSentry, InPower and "Our energy working for you." are trademarks of Cummins Power Generation. Other company, product, or service names may be trademarks or service marks of others. Specifications are subject to change without notice. S-1570b (5/10) Page 2 of 12



- Voltage (single or three phase line-to-line and line-to-neutral)
- Current (single or three phase)
- kW, KVAR, power factor, KVA (three phase and total)
- Frequency

For Lean Burn Natural Gas Engine applications:

- Alternator heater status
- Alternator winding temperature (per phase)
- Alternator drive end bearing temperature
- Alternator non-drive end bearing temperature

#### Utility/AC bus data

- Voltage (three phase line-to-line and line-to-neutral)
- Current (three phase and total)
- kW, KVAR, power factor, KVA (three phase and total)
- Frequency

#### Engine data

- Starting battery voltage
- Engine speed
- Engine temperature
- Engine oil pressure
- Engine oil temperature
- Intake manifold temperature
- Coolant temperature
- Comprehensive Full Authority Engine (FAE) data (where applicable)

For Lean Burn Natural Gas Engine applications:

- Safety shutoff valve status
- Valve proving status
- Downstream gas pressure
- Gas inlet pressure
- Gas mass flow rate
- Control valve position
- Gas outlet pressure
- Manifold pressure
- Manifold temperature
- Throttle position
- Compressor outlet pressure
- Turbo speed
- Compressor bypass position
- Cylinder configuration (e.g., drive end and non-drive end configurations)
- Coolant pressure 1 and 2 (e.g., HT and LT)
- Coolant temperature 1 and 2 (e.g., HT and LT)
- Exhaust port temperature (up to 18 cylinders)
- Pre-filter oil pressure
- Exhaust back pressure
- CM700 internal temperature
- CM700 isolated battery voltage
- Speed bias
- CM558 internal temperature
- CM558 isolated battery voltage
- Knock level (up to 18 cylinders)
- Spark advance (up to 18 cylinders)
- Knock count (up to 18 cylinders)
- Auxiliary supply disconnect status

- Engine heater status
- Coolant circulating pump status
- Lube oil priming pump status
- Lube oil status
- Oil heater status
- Derate authorization status
- Start system status
- Ventilator fan status
- Ventilation louvre status
- Radiator fan status
- DC PSU status
- Start inhibit/enable status and setup

Service adjustments – The HMI includes provisions for adjustment and calibration of genset control functions. Adjustments are protected by a password. Functions include:

- Engine speed governor adjustments
- Voltage regulation adjustments
- Cycle cranking
- Configurable fault set up
- Configurable input and output set up
- Meter calibration
- Paralleling setup
- Display language and units of measurement

#### **Engine control**

SAE-J1939 CAN interface to full authority ECMs (where applicable). Provides data transfer between genset and engine controller for control, metering and diagnostics.

12 VDC/24 VDC battery operations - PowerCommand will operate either on 12 VDC or 24 VDC batteries.

Temperature dependent governing dynamics (with electronic governing) - modifies the engine governing control parameters as a function of engine temperature. This allows the engine to be more responsive when warm and more stable when operating at lower temperature levels.

Isochronous governing - (where applicable) Capable of controlling engine speed within +/-0.25% for any steady state load from no load to full load. Frequency drift will not exceed +/-0.5% for a 33 °C (60 °F) change in ambient temperature over an 8 hour period.

Droop electronic speed governing - Control can be adjusted to droop from 0 to 10% from no load to full load.

Remote start mode - It accepts a ground signal from remote devices to automatically start the genset and immediately accelerates to rated speed and voltage or run at idle until engine temperature is adequate. The remote start signal will also wake up the control from sleep mode. The control can incorporate a time delay start and stop.

Our energy working for you.™

[www.cumminspower.com](http://www.cumminspower.com)

©2010 Cummins Power Generation Inc. All rights reserved. Cummins Power Generation and Cummins are registered trademarks of Cummins Inc. PowerCommand, AmpSentry, InPower and "Our energy working for you." are trademarks of Cummins Power Generation. Other company, product, or service names may be trademarks or service marks of others. Specifications are subject to change without notice. S-1570b (5/10) Page 3 of 12



Remote and local emergency stop - The control accepts a ground signal from a local (genset mounted) or remote (facility mounted) emergency stop switch to cause the genset to immediately shut down. The genset is prevented from running or cranking with the switch engaged. In sleep mode, activation of either emergency stop switch will wake up the control.

Sleep mode - The control includes a configurable low current draw state to minimize starting battery current draw when the genset is not operating. The control can also be configured to go into a low current state while in auto for prime applications or applications without a battery charger.

Engine starting - The control system supports automatic engine starting. Primary and backup start disconnects are achieved by one of two methods: magnetic pickup or main alternator output frequency. The control also supports configurable glow plug control when applicable.

Cycle cranking - Is configurable for the number of starting cycles (1 to 7) and duration of crank and rest periods. Control includes starter protection algorithms to prevent the operator from specifying a starting sequence that might be damaging.

Time delay start and stop (cooldown) - Configurable for time delay of 0-300 seconds prior to starting after receiving a remote start signal and for time delay of 0-600 seconds prior to shut down after signal to stop in normal operation modes. Default for both time delay periods is 0 seconds.

For Lean Burn Natural Gas Engine applications:

Engine start inhibit/enable - The function will allow application-specific processes to be started prior to the genset/engine start (e.g., pumps, boosters, etc.).

## **Alternator control**

The control includes an integrated three phase line-to-line sensing voltage regulation system that is compatible with shunt or PMG excitation systems. The voltage regulation system is a three phase full wave rectified and has an FET output for good motor starting capability. Major system features include:

Digital output voltage regulation - Capable of regulating output voltage to within +/-1.0% for any loads between no load and full load. Voltage drift will not exceed +/-1.5% for a 40 °C (104 °F) change in temperature in an eight hour period. On engine starting or sudden load acceptance, voltage is controlled to a maximum of 5% overshoot over nominal level.

The automatic voltage regulator feature can be disabled to allow the use of an external voltage regulator.

Droop voltage regulation - Control can be adjusted to droop from 0-10% from no load to full load.

Torque-matched V/Hz overload control - The voltage roll-off set point and rate of decay (i.e. the slope of the V/Hz curve) is adjustable in the control.

Fault current regulation - PowerCommand will regulate the output current on any phase to a maximum of three times rated current under fault conditions for both single phase and three phase faults. In conjunction with a permanent magnet generator, it will provide three times rated current on all phases for motor starting and short circuit coordination purpose.

## **Paralleling functions**

**First Start Sensor™ system** - PowerCommand provides a unique control function that positively prevents multiple gensets from simultaneously closing to an isolated bus under black start conditions. The First Start Sensor system is a communication system between the gensets that allows the gensets to work together to determine which genset in a system should be the first to close to the bus. The system includes an independent backup function, so that if the primary system is disabled the required functions are still performed.

**Synchronizing** - Control incorporates a digital synchronizing function to force the genset to match the frequency, phase and voltage of another source such as a utility grid. The synchronizer includes provisions to provide proper operation even with highly distorted bus voltage waveforms. The synchronizer can match other sources over a range of 60-110% of nominal voltage and -24 to +6 hertz. The synchronizer function is configurable for slip frequency synchronizing for applications requiring a known direction of power flow at instant of breaker closure or for applications where phase synchronization performance is otherwise inadequate.

**Load sharing control** - The genset control includes an integrated load sharing control system for both real (kW) and reactive (kVar) loads when the genset(s) are operating on an isolated bus. The control system determines kW load on the engine and kVar load on the alternator as a percent of genset capacity, and then regulates fuel and excitation systems to maintain system and genset at the same percent of load without impacting voltage or frequency regulation. The control can also be configured for operation in droop mode for kW or Kvar load sharing.

Our energy working for you.™

[www.cumminspower.com](http://www.cumminspower.com)

©2010 Cummins Power Generation Inc. All rights reserved. Cummins Power Generation and Cummins are registered trademarks of Cummins Inc. PowerCommand, AmpSentry, InPower and "Our energy working for you." are trademarks of Cummins Power Generation. Other company, product, or service names may be trademarks or service marks of others. Specifications are subject to change without notice. S-1570b (5/10) Page 4 of 12



**Load govern control** – When PowerCommand receives a signal indicating that the genset is paralleled with an infinite source such as a utility (mains) service, the genset will operate in load govern mode. In this mode the genset will synchronize and close to the bus, ramp to a pre-programmed kW and kVar load level, and then operate at that point. Control is adjustable for kW values from 0-100% of standby rating, and 0.7-1.0 power factor (lagging). Default setting is 80% of standby and 1.0 power factor. The control includes inputs to allow independent control of kW and kVar load level by a remote device while in the load govern mode. The rate of load increase and decrease is also adjustable in the control. In addition, the control can be configured for operation in kW or kVAR load govern droop.

**Load demand control** – The control system includes the ability to respond to an external signal to initiate load demand operation. On command, the genset will ramp to no load, open its paralleling breaker, cool down, and shut down. On removal of the command, the genset will immediately start, synchronize, connect, and ramp to its share of the total load on the system.

**Sync check** – The sync check function decides when permissive conditions have been met to allow breaker closure. Adjustable criteria are: phase difference from 0.1-20 deg, frequency difference from 0.001-1.0 Hz, voltage difference from 0.5-10%, and a dwell time from 0.5-5.0 sec. Internally the sync check is used to perform closed transition operations. An external sync check output is also available.

**Genset and utility/AC bus source AC metering** – The control provides comprehensive three phase AC metering functions for both monitored sources, including: 3-phase voltage (L-L and L-N) and current, frequency, phase rotation, individual phase and totalized values of kW, kVAR, kVA and Power Factor; totalized positive and negative kW-hours, kVAR-hours, and kVA-hours. Three wire or four wire voltage connection with direct sensing of voltages to 600V, and up to 45kV with external transformers. Current sensing is accomplished with either 5 amp or 1 CT secondaries and with up to 10,000 amp primary. Maximum power readings are 32,000kW/kVAR/kVA.

**Power transfer control** – provides integrated automatic power transfer functions including source availability sensing, genset start/stop and transfer pair monitoring and control. The transfer/retransfer is configurable for open transition, fast closed transition (less than 100msec interconnect time), or soft closed transition (load ramping) sequences of operation. Utility source failure will automatically start genset and transfer load, retransferring when utility source returns. Test will start gensets and transfer load if test with load is enabled. Sensors and timers include:

Under voltage sensor: 3-phase L-N or L-L under voltage sensing adjustable for pickup from 85-100% of nominal. Dropout adjustable from 75-98% of pickup. Dropout delay adjustable from 0.1-30 sec.

Over voltage sensor: 3-phase L-N or L-L over voltage sensing adjustable for pickup from 95-99% of dropout. Dropout adjustable from 105-135% of nominal. Dropout delay adjustable from 0.5-120 sec. Standard configuration is disabled, and is configurable to enabled in the field using the HMI or InPower service tools.

Over/Under frequency sensor: Center frequency adjustable from 45-65 Hz. Dropout bandwidth adjustable from 0.3-5% of center frequency beyond pickup bandwidth. Pickup bandwidth adjustable from 0.3-20% of center frequency. Field configurable to enable.

Loss of phase sensor: Detects out of range voltage phase angle relationship. Field configurable to enable.

Phase rotation sensor: Checks for valid phase rotation of source. Field configurable to enable.

Breaker tripped: If the breaker tripped input is active, the associated source will be considered as unavailable.

Timers: Control provides adjustable start delay from 0-300sec, stop delay from 0-800sec, transfer delay from 0-120sec, retransfer delay from 0-1800sec, programmed transition delay from 0-60sec, and maximum parallel time from 0-1800sec.

**Breaker control** – Utility and Genset breaker interfaces include separate relays for opening and closing breaker, as well as inputs for both 'a' and 'b' breaker position contacts and tripped status. Breaker diagnostics include Contact Failure, Fail to Close, Fail to Open, Fail to Disconnect, and Tripped. Upon breaker failure, appropriate control action is taken to maintain system integrity.

**Extended paralleling** – In extended paralleling mode (when enabled) the controller will start the genset and parallel to a utility source and then govern the real and reactive power output of the genset based on the desired control point. The control point for the real power (kW) can be configured for either the genset metering point ("Base Load") or the utility metering point ("Peak Shave"). The control point for the reactive power (kVAR or Power Factor) can also be independently configured for either the genset metering point or the utility metering point. This flexibility would allow base kW load from the genset while maintaining the utility power factor at a reasonable value to avoid penalties due to low power factor. The System always operates within genset ratings. The control point can be changed while the system is in operation. Set points can be adjusted via hardwired analog input or adjusted through an operator panel display or service tool.

Our energy working for you.™

[www.cumminspower.com](http://www.cumminspower.com)

©2010 Cummins Power Generation Inc. All rights reserved. Cummins Power Generation and Cummins are registered trademarks of Cummins Inc. PowerCommand, AmpSentry, InPower and "Our energy working for you." are trademarks of Cummins Power Generation. Other company, product, or service names may be trademarks or service marks of others. Specifications are subject to change without notice. S-1570b (5/10) Page 5 of 12



**Exerciser clock** –The exerciser clock (when enabled) allows the system to be operated at preset times in either test without load, test with load, or extended parallel mode. A Real Time Clock is built in. Up to 12 different programs can be set for day of week, time of day, duration, repeat interval, and mode. For example, a test with load for 1 hour every Tuesday at 2AM can be programmed. Up to 6 different exceptions can also be set up to block a program from running during a specific date and time period.

**Application types** – Controller is configured to operating in one of six possible application types. These topologies are often used in combinations in larger systems, with coordination of the controllers in the system either by external device or by interlocks provided in the control. Topologies that may be selected in the control include:

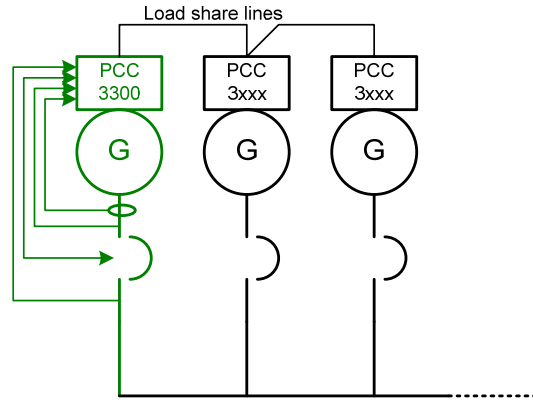

**Standalone:** Control provides monitoring, protection and control in a non-paralleling application.

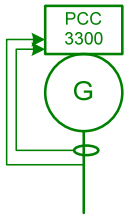

**Synchronizer only:** control will synchronize the genset to other source when commanded to either via a hardwired or Modbus driven input.

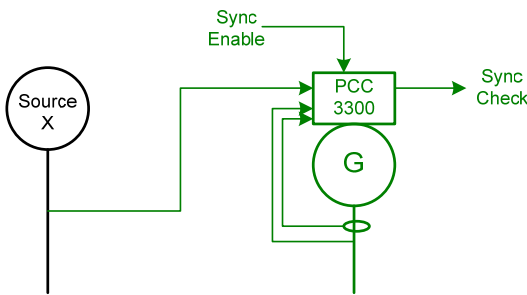

**Utility Single:** Control monitors one genset and utility. The control will automatically start and provide power to a load if the utility fails. The control will also resynchronize the genset back to the utility and provides extended paralleling capabilities.

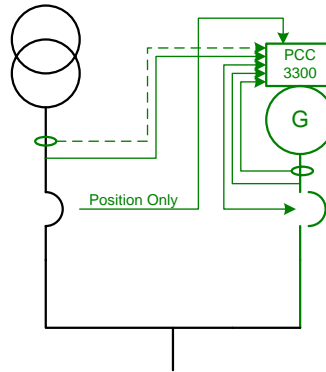

**Utility Multiple:** Supports all functionality of Isolated Bus and provides extended paralleling to the utility. Extended paralleling load set points follow a constant setting; dynamically follow an analog input, Modbus register or HMI.

**Isolated Bus:** allows the genset to perform a dead bus closure or synchronize to the bus and isochronously share kW and kVAR loads with other gensets.

Our energy working for you.™

[www.cumminspower.com](http://www.cumminspower.com)

©2010 Cummins Power Generation Inc. All rights reserved. Cummins Power Generation and Cummins are registered trademarks of Cummins Inc. PowerCommand, AmpSentry, InPower and "Our energy working for you." are trademarks of Cummins Power Generation. Other company, product, or service names may be trademarks or service marks of others. Specifications are subject to change without notice. S-1570b (5/10) Page 6 of 12



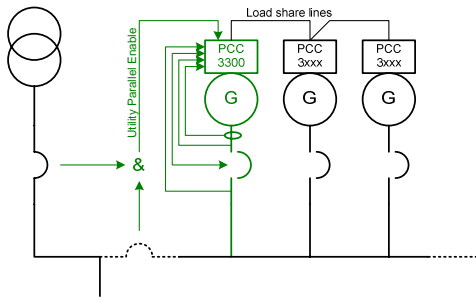

**Power Transfer Control:** control operates a single genset/single utility transfer pair in open transition, fast closed transition, or soft closed transition. Extended paralleling functionality also provides base load and peak shave options.

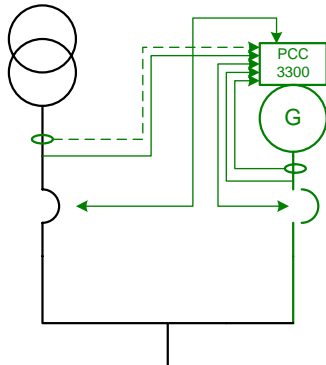

## Protective functions

On operation of a protective function the control will indicate a fault by illuminating the appropriate status LED on the HMI, as well as display the fault code and fault description on the LCD. The nature of the fault and time of occurrence are logged in the control. The service manual and InPower service tool provide service keys and procedures based on the service codes provided. Protective functions include:

### Battle short mode

When enabled and the *battle short* switch is active, the control will allow some shutdown faults to be bypassed. If a bypassed shutdown fault occurs, the fault code and description will still be annunciated, but the genset will not shutdown. This will be followed by a *fail to shutdown* fault. Emergency stop shutdowns and others that are critical for proper operation (or are handled by the engine ECM) are not bypassed. Please refer to the Control Application Guide or Manual for list of these faults.

### Derate

The Derate function reduces output power of the genset in response to a fault condition. If a Derate command occurs while operating on an isolated bus, the control will issue commands to reduce the load on the genset via contact closures or Modbus. If a Derate command occurs while in utility parallel mode, the control will actively reduce power by lowering the base load kW to the derated target kW.

Our energy working for you.™

[www.cumminspower.com](http://www.cumminspower.com)

©2010 Cummins Power Generation Inc. All rights reserved. Cummins Power Generation and Cummins are registered trademarks of Cummins Inc. PowerCommand, AmpSentry, InPower and "Our energy working for you." are trademarks of Cummins Power Generation. Other company, product, or service names may be trademarks or service marks of others. Specifications are subject to change without notice. S-1570b (5/10) Page 7 of 12

## Configurable alarm and status inputs

The control accepts up to four alarm or status inputs (configurable contact closed to ground or open) to indicate a configurable (customer-specified) condition.

The control is programmable for warning, derate, shutdown, shutdown with cooldown or status indication and for labeling the input.

## Emergency stop

Annunciated whenever either emergency stop signal is received from external switch.

## General engine protection

Low and high battery voltage warning - Indicates status of battery charging system (failure) by continuously monitoring battery voltage.

Weak battery warning - The control system will test the battery each time the genset is signaled to start and indicate a warning if the battery indicates impending failure.

Fail to start (overcrank) shutdown - The control system will indicate a fault if the genset fails to start by the completion of the engine crank sequence.

Fail to crank shutdown - Control has signaled starter to crank engine but engine does not rotate.

Cranking lockout - The control will not allow the starter to attempt to engage or to crank the engine when the engine is rotating.

Fault simulation - The control in conjunction with InPower software, will accept commands to allow a technician to verify the proper operation of the control and its interface by simulating failure modes or by forcing the control to operate outside of its normal operating ranges. InPower also provides a complete list of faults and settings for the protective functions provided by the controller.

For Lean Burn Natural Gas Engine applications:

Off load running (protection) - This feature protects the engine in the event the genset is being called to go off load for too long.

## Hydro mechanical fuel system engine protection

Overspeed shutdown - Default setting is 115% of nominal

Low lube oil pressure warning/shutdown - Level is preset (configurable with InPower or HMI) to match the capabilities of the engine used. Control includes time delays to prevent nuisance alarms.

High lube oil temperature warning/shutdown - Level is preset (configurable with InPower or HMI) to match the capabilities of the engine used. Control includes time delays to prevent nuisance alarms.



High engine temperature warning/shutdown – Level is preset (configurable with InPower or HMI) to match the capabilities of the engine used. Control includes time delays to prevent nuisance alarms.

Low coolant temperature warning – Indicates that engine temperature may not be high enough for a 10 second start or proper load acceptance.

Low coolant temperature warning – Can be set up to be a warning or shutdown.

High intake manifold temperature shutdown – Level is preset (configurable with InPower or HMI) to match the capabilities of the engine used. Control includes time delays to prevent nuisance alarms.

### Full authority electronic engine protection

Engine fault detection is handled inside the engine ECM. Fault information is communicated via the SAE-J1939 data link for annunciation in the HMI.

### Alternator protection

AmpSentry protective relay - A comprehensive monitoring and control system integral to the PowerCommand Control System that guards the electrical integrity of the alternator and power system by providing protection against a wide array of fault conditions in the genset or in the load. It also provides single and three phase fault current regulation so that downstream protective devices have the maximum current available to quickly clear fault conditions without subjecting the alternator to potentially catastrophic failure conditions. See document R1053 for a full size time over current curve. The control does not include protection required for interconnection to a utility (mains) service.

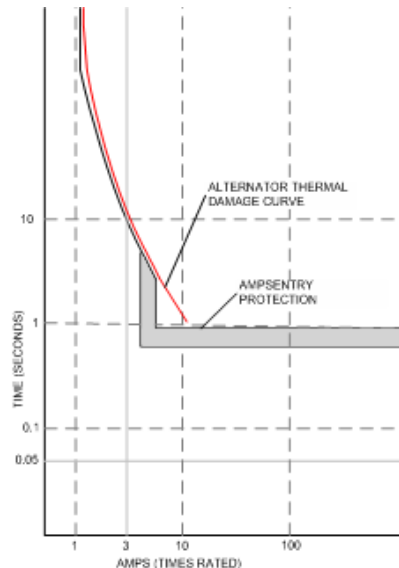

High AC voltage shutdown (59) - Output voltage on any phase exceeds preset values. Time to trip is inversely proportional to amount above threshold. Values adjustable from 105-125% of nominal voltage, with time delay adjustable from 0.1-10 seconds. Default value is 110% for 10 seconds.

Low AC voltage shutdown (27) - Voltage on any phase has dropped below a preset value. Adjustable over a range of 50-95% of reference voltage, time delay 2-20 seconds. Default value is 85% for 10 seconds. Function tracks reference voltage. Control does not nuisance trip when voltage varies due to the control directing voltage to drop, such as during a V/Hz roll-off or synchronizing.

Under frequency shutdown (81 u) - Genset output frequency cannot be maintained. Settings are adjustable from 2-10 Hz below reference governor set point, for a 5-20 second time delay. Default: 6 Hz, 10 seconds. Under frequency protection is disabled when excitation is switched off, such as when engine is operating in idle speed mode.

Over frequency shutdown/warning (81o) - Genset is operating at a potentially damaging frequency level. Settings are adjustable from 2-10 Hz above nominal governor set point for a 1-20 second time delay. Default: 6 Hz, 20 seconds, disabled.

Overcurrent warning/shutdown (51) - Implementation of the thermal damage curve with instantaneous trip level calculated based on current transformer ratio and application power rating.

Loss of sensing voltage shutdown - Shutdown of genset will occur on loss of voltage sensing inputs to the control.

Field overload shutdown - Monitors field voltage to shutdown genset when a field overload condition occurs.

Over load (kW) warning - Provides a warning indication when engine is operating at a load level over a set point. Adjustment range: 80-140% of application rated kW, 0-120 second delay. Defaults: 105%, 60 seconds.

Reverse power shutdown (32) - Adjustment range: 5-20% of standby kW rating, delay 1-15 seconds. Default: 10%, 3 seconds.

Reverse Var shutdown - Shutdown level is adjustable: 15-50% of rated Var output, delay 10-60 seconds. Default: 20%, 10 seconds.

Short circuit protection - Output current on any phase is more than 175% of rating and approaching the thermal damage point of the alternator. Control includes algorithms to protect alternator from repeated over current conditions over a short period of time.

Negative sequence overcurrent warning (46) – Control protects the generator from damage due to excessive imbalances in the three phase load currents and/or power factors.

Our energy working for you.™

[www.cumminspower.com](http://www.cumminspower.com)

©2010 Cummins Power Generation Inc. All rights reserved. Cummins Power Generation and Cummins are registered trademarks of Cummins Inc. PowerCommand, AmpSentry, InPower and "Our energy working for you." are trademarks of Cummins Power Generation. Other company, product, or service names may be trademarks or service marks of others. Specifications are subject to change without notice. S-1570b (5/10) Page 8 of 12



Custom overcurrent warning/shutdown (51) – Control provides the ability to have a custom time overcurrent protection curve in addition to the AmpSentry protective relay function.

Ground fault overcurrent (51G) – Control detects a ground fault either by an external ground fault relay via a contact input or the control can measure the ground current from an external current transformer. Associated time delays and thresholds are adjustable via InPower or HMI.

### **Paralleling protection**

Breaker fail to close Warning: When the control signals a circuit breaker to close, it will monitor the breaker auxiliary contacts and verify that the breaker has closed. If the control does not sense a breaker closure within an adjustable time period after the close signal, the fail to close warning will be initiated.

Breaker fail to open warning: The control system monitors the operation of breakers that have been signaled to open. If the breaker does not open within an adjustable time delay, a Breaker Fail to Open warning is initiated.

Breaker position contact warning: The controller will monitor both ‘a’ and ‘b’ position contacts from the breaker. If the contacts disagree as to the breaker position, the breaker position contact warning will be initiated.

Breaker tripped warning: The control accepts inputs to monitor breaker trip / bell alarm contact and will initiate a breaker tripped warning if it should activate.

Fail to disconnect warning: In the controller is unable to open either breaker, a fail to disconnect warning is initiated. Typically this would be mapped to a configurable output, allowing an external device to trip a breaker.

Fail to synchronize warning: Indicates that the genset could not be brought to synchronization with the bus. Configurable for adjustable time delay of 10 -900 seconds, 120 default.

Phase sequence sensing warning: Verifies that the genset phase sequence matches the bus prior to allowing the paralleling breaker to close.

Maximum parallel time warning (power transfer control mode only): During closed transition load transfers, control independently monitors paralleled time. If time is exceeded, warning is initiated and genset is disconnected.

Bus or genset PT input calibration warning: The control system monitors the sensed voltage from the bus and genset output voltage potential transformers. When the paralleling breaker is closed, it will indicate a warning condition if the read values are different.

## **Field control interface**

### **Input signals to the PowerCommand control include:**

- Coolant level (where applicable)
- Fuel level (where applicable)
- Remote emergency stop
- Remote fault reset
- Remote start
- Rupture basin
- Start type signal
- Battle short
- Load demand stop
- Synchronize enable
- Genset circuit breaker inhibit
- Utility circuit breaker inhibit
- Single mode verify
- Transfer inhibit – prevent transfer to utility (in power transfer control mode)
- Retransfer inhibit – prevent retransfer to genset (in power transfer control mode)
- kW and kVAR load setpoints
- Configurable inputs - Control includes (4) input signals from customer discrete devices that are configurable for warning, shutdown or status indication, as well as message displayed

For Lean Burn Natural Gas Engine applications:

- Gearbox oil pressure/temperature protection
- Fire fault
- Earth fault
- Differential fault
- DC power supply fault
- Genset Interface Box (GIB) isolator open fault
- Start inhibit/enable (x3)
- Radiator fan trip
- Ventilator fan trip
- Ventilation louvers closed
- Start system trip
- Alternator heater trip
- Alternator heater status
- Alternator winding temperature (PT100 RTDx3)
- Alternator drive end bearing temperature (PT100 RTD)
- Alternator non-drive end bearing temperature (PT100 RTD)

### **Output signals from the PowerCommand control include:**

- Load dump signal: Operates when the genset is in an overload condition.
- Delayed off signal: Time delay based output which will continue to remain active after the control has removed the run command. Adjustment range: 0 - 120 seconds. Default: 0 seconds.

Our energy working for you.™

[www.cumminspower.com](http://www.cumminspower.com)

©2010 Cummins Power Generation Inc. All rights reserved. Cummins Power Generation and Cummins are registered trademarks of Cummins Inc. PowerCommand, AmpSentry, InPower and "Our energy working for you." are trademarks of Cummins Power Generation. Other company, product, or service names may be trademarks or service marks of others. Specifications are subject to change without notice. S-1570b (5/10) Page 9 of 12



- Configurable relay outputs: Control includes (4) relay output contacts (3 A, 30VDC). These outputs can be configured to activate on any control warning or shutdown fault as well as ready to load, not in auto, common alarm, common warning and common shutdown.
- Ready to load (genset running) signal: Operates when the genset has reached 90% of rated speed and voltage and latches until genset is switched to off or idle mode.
- Paralleling circuit breaker relays outputs: Control includes (4) relay output contacts (3.5A, 30 VDC) for opening and closing of the genset and utility breakers.

For Lean Burn Natural Gas Engine applications:

- Start inhibit/enable event
- Emergency stop event
- Ventilator fan run control
- Louvre control
- Radiator fan control
- Alternator heater control
- Engine at idle speed event

**Communications connections include:**

- PC tool interface: This RS-485 communication port allows the control to communicate with a personal computer running InPower software.
- Modbus RS-485 port: Allows the control to communicate with external devices such as PLCs using Modbus protocol.

Note - An RS-232 or USB to RS-485 converter is required for communication between PC and control.

- Networking: This RS-485 communication port allows connection from the control to the other Cummins Power Generation products.

**Mechanical drawing**

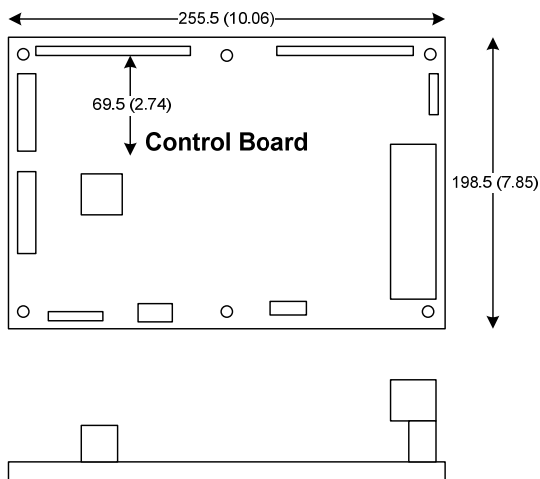

**PowerCommand human machine interface HMI320**



**Description**

This control system includes an intuitive operator interface panel that allows for complete genset control as well as system metering, fault annunciation, configuration and diagnostics. The interface includes five genset status LED lamps with both internationally accepted symbols and English text to comply with customers needs. The interface also includes an LED backlit LCD display with tactile feel soft-switches for easy operation and screen navigation. It is configurable for units of measurement and has adjustable screen contrast and brightness.

The *run/off/auto* switch function is integrated into the interface panel.

All data on the control can be viewed by scrolling through screens with the navigation keys. The control displays the current active fault and a time-ordered history of the five previous faults.

**Features:**

- LED indicating lamps
  - genset running
  - remote start
  - not in auto
  - shutdown
  - warning
  - auto
  - manual and stop
  - Circuit breaker open (if equipped)
  - Circuit breaker closed (if equipped)
- 320 x 240 pixels graphic LED backlight LCD.
- Four tactile feel membrane switches for LCD defined operation. The functions of these switches are defined dynamically on the LCD.
- Seven tactile feel membrane switches dedicated screen navigation buttons for up, down, left, right, ok, home and cancel.

Our energy working for you.™

[www.cumminspower.com](http://www.cumminspower.com)



- Six tactile feel membrane switches dedicated to control for auto, stop, manual, manual start, fault reset and lamp test/panel lamps.
- Two tactile feel membrane switches dedicated to control of circuit breaker (where applicable).
- Allows for complete genset control setup.
- Certifications: Suitable for use on gensets that are designed, manufactured, tested and certified to relevant UL, NFPA, ISO, IEC, Mil Std. and CE standards.
- LCD languages supported: English, Spanish, French, German, Italian, Greek, Dutch, Portuguese, Finnish, Norwegian, Danish, Russian and Chinese Characters.

#### Communications connections include:

- PC tool interface - This RS-485 communication port allows the HMI to communicate with a personal computer running InPower.
- This RS-485 communication port allows the HMI to communicate with the main control board.

#### Mechanical drawing

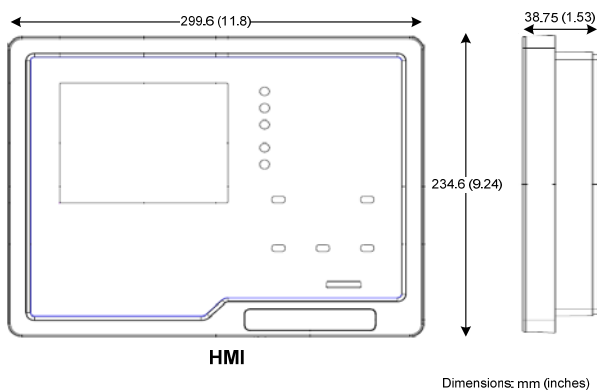

#### Software

InPower (beyond 6.5 version) is a PC-based software service tool that is designed to directly communicate to PowerCommand gensets and transfer switches, to facilitate service and monitoring of these products.

#### Environment

The control is designed for proper operation without recalibration in ambient temperatures from -40 °C (-40 °F) to +70° C (158 °F), and for storage from -55 °C (-67 °F) to +80 °C (176 °F). Control will operate with humidity up to 95%, non-condensing.

The HMI is designed for proper operation in ambient temperatures from -20 °C (-4 °F) to +70 °C (158 °F), and for storage from -30 °C (-22 °F) to +80 °C (176 °F).

The control board is fully encapsulated to provide superior resistance to dust and moisture. Display panel has a single membrane surface, which is impervious to effects of dust, moisture, oil and exhaust fumes. This panel uses a sealed membrane to provide long reliable service life in harsh environments.

The control system is specifically designed and tested for resistance to RFI/EMI and to resist effects of vibration to provide a long reliable life when mounted on a genset. The control includes transient voltage surge suppression to provide compliance to referenced standards.

#### Certifications

PowerCommand meets or exceeds the requirements of the following codes and standards:

- NFPA 110 for level 1 and 2 systems.
- ISO 8528-4: 1993 compliance, controls and switchgear.
- CE marking: The control system is suitable for use on generator sets to be CE-marked.
- EN 50081-1,2 residential/light industrial emissions or industrial emissions.
- EN 50082-1,2 residential/light industrial or industrial susceptibility.
- ISO 7637-2, level 2; DC supply surge voltage test.
- Mil Std 202C, Method 101 and ASTM B117: Salt fog test.
- UL 508 recognized or Listed and suitable for use on UL 2200 Listed generator sets.
- CSA C282-M1999 compliance
- CSA 22.2 No. 14 M91 industrial controls.
- PowerCommand control systems and generator sets are designed and manufactured in ISO 9001 certified facilities.

#### Warranty

All components and subsystems are covered by an express limited one year warranty. Other optional and extended factory warranties and local distributor maintenance agreements are available.

Our energy working for you.™

[www.cumminspower.com](http://www.cumminspower.com)

©2010 Cummins Power Generation Inc. All rights reserved. Cummins Power Generation and Cummins are registered trademarks of Cummins Inc. PowerCommand, AmpSentry, InPower and "Our energy working for you." are trademarks of Cummins Power Generation. Other company, product, or service names may be trademarks or service marks of others. Specifications are subject to change without notice. S-1570b (5/10) Page 11 of 12



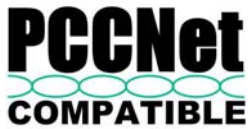

**See your distributor for more information**

**Cummins Power Generation**

**Americas**

1400 73<sup>rd</sup> Avenue N.E.  
Minneapolis, MN 55432 USA  
Phone: 763 574 5000  
Fax: 763 574 5298

**Europe, CIS, Middle East and Africa**

Manston Park Columbus Ave.  
Manston Ramsgate  
Kent CT 12 5BF United Kingdom  
Phone 44 1843 255000  
Fax 44 1843 255902

**Asia Pacific**

10 Toh Guan Road #07-01  
TT International Tradepark  
Singapore 608838  
Phone 65 6417 2388  
Fax 65 6417 2399

**Warning:** Back feed to a utility system can cause electrocution and/or property damage. Do not connect to any building's electrical system except through an approved device or after building main switch is open.

Our energy working for you.™

[www.cumminspower.com](http://www.cumminspower.com)

©2010 Cummins Power Generation Inc. All rights reserved. Cummins Power Generation and Cummins are registered trademarks of Cummins Inc. PowerCommand, AmpSentry, InPower and "Our energy working for you." are trademarks of Cummins Power Generation. Other company, product, or service names may be trademarks or service marks of others. Specifications are subject to change without notice. S-1570b (5/10) Page 12 of 12



# STAMFORD<sup>®</sup>

## PI734A - Technical Data Sheet

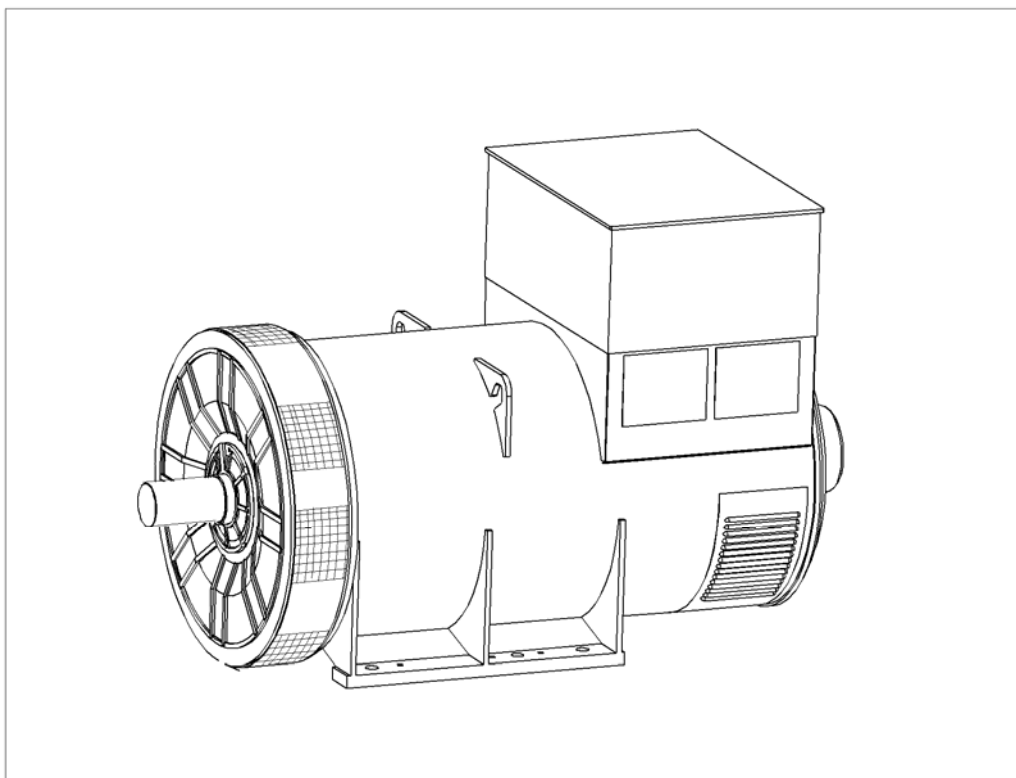

## PI734A

## SPECIFICATIONS &amp; OPTIONS

**STANDARDS**

Newage Stamford industrial generators meet the requirements of BS EN 60034 and the relevant sections of other national and international standards such as BS5000, VDE 0530, NEMA MG1-32, IEC60034, CSA C22.2-100, AS1359.

Other standards and certifications can be considered on request.

**DESCRIPTION**

The STAMFORD PI range of synchronous ac generators are brushless with a rotating field. They are separately excited by the STAMFORD Permanent Magnet Generator (PMG). This is a shaft mounted, high frequency, pilot exciter which provides a constant supply of clean power via the Automatic Voltage Regulator (AVR) to the main exciter. The main exciter output is fed to the main rotor, through a full wave bridge rectifier, protected by surge suppression.

**VOLTAGE REGULATORS**

The PI range generators, complete with a PMG, are available with one of two AVRs. Each AVR has soft start voltage build up and built in protection against sustained over-excitation, which will de-excite the generator after a minimum of 8 seconds.

Underspeed protection (UFRO) is also provided on both AVRs. The UFRO will reduce the generator output voltage proportional to the speed of the generator below a pre-settable level.

The **MX341 AVR** is two phase sensed with a voltage regulation of  $\pm 1\%$ . (see the note on regulation).

The **MX321 AVR** is 3 phase rms sensed with a voltage regulation of 0.5% rms (see the note on regulation). The UFRO circuit has adjustable slope and dwell for controlled recovery from step loads. An over voltage protection circuit will shutdown the output device of the AVR, it can also trip an optional excitation circuit breaker if required. As an option, short circuit current limiting is available with the addition of current transformers.

Both the MX341 and the MX321 need a generator mounted current transformer to provide quadrature droop characteristics for load sharing during parallel operation. Provision is also made for the connection of the STAMFORD power factor controller, for embedded applications, and a remote voltage trimmer.

**WINDINGS & ELECTRICAL PERFORMANCE**

All generator stators are wound to 2/3 pitch. This eliminates triplen (3rd, 9th, 15th ...) harmonics on the voltage waveform and is found to be the optimum design for trouble-free supply of non-linear loads. The 2/3 pitch design avoids excessive neutral currents sometimes seen with higher winding pitches. A fully connected damper winding reduces oscillations during paralleling. This winding, with the 2/3 pitch and carefully selected pole and tooth designs, ensures very low levels of voltage waveform distortion.

**TERMINALS & TERMINAL BOX**

Standard generators feature a main stator with 6 ends brought out to the terminals, which are mounted on the frame at the non-drive end of the generator. A sheet steel terminal box contains the AVR and provides ample space for the customers' wiring and gland arrangements. It has removable panels for easy access.

**SHAFT & KEYS**

All generator rotors are dynamically balanced to better than BS6861:Part 1 Grade 2.5 for minimum vibration in operation. Two bearing generators are balanced with a half key.

**INSULATION/IMPREGNATION**

The insulation system is class 'H', and meets the requirements of UL1446.

All wound components are impregnated with materials and processes designed specifically to provide the high build required for static windings and the high mechanical strength required for rotating components.

**QUALITY ASSURANCE**

Generators are manufactured using production procedures having a quality assurance level to BS EN ISO 9001.

**NOTE ON REGULATION**

The stated voltage regulation may not be maintained in the presence of certain radio transmitted signals. Any change in performance will fall within the limits of Criteria 'B' of EN 61000-6-2:2001. At no time will the steady-state voltage regulation exceed 2%.

Note: Continuous development of our products entitles us to change specification details without notice, therefore they must not be regarded as binding.

Front cover drawing is typical of the product range.

# PI734A

## WINDING 312

**STAMFORD**

CONTROL SYSTEM	SEPARATELY EXCITED BY P.M.G.		
A.V.R.	MX341	MX321	
VOLTAGE REGULATION	± 1%	± 0.5 %	With 4% ENGINE GOVERNING
SUSTAINED SHORT CIRCUIT	REFER TO SHORT CIRCUIT DECREMENT CURVES (page 7)		

INSULATION SYSTEM	CLASS H
PROTECTION	IP23
RATED POWER FACTOR	0.8
STATOR WINDING	DOUBLE LAYER LAP
WINDING PITCH	TWO THIRDS
WINDING LEADS	6
MAIN STATOR RESISTANCE	0.0016 Ohms PER PHASE AT 22°C STAR CONNECTED
MAIN ROTOR RESISTANCE	1.67 Ohms at 22°C
EXCITER STATOR RESISTANCE	17.5 Ohms at 22°C
EXCITER ROTOR RESISTANCE	0.063 Ohms PER PHASE AT 22°C
R.F.I. SUPPRESSION	BS EN 61000-6-2 & BS EN 61000-6-4, VDE 0875G, VDE 0875N. refer to factory for others
WAVEFORM DISTORTION	NO LOAD < 1.5% NON-DISTORTING BALANCED LINEAR LOAD < 5.0%
MAXIMUM OVERSPEED	2250 Rev/Min
BEARING DRIVE END	BALL. 6228 C3
BEARING NON-DRIVE END	BALL. 6319 C3

	1 BEARING	2 BEARING
WEIGHT COMP. GENERATOR	2760 kg	2710 kg
WEIGHT WOUND STATOR	1306 kg	1306 kg
WEIGHT WOUND ROTOR	1139 kg	1077 kg
WR <sup>2</sup> INERTIA	32.7498 kgm <sup>2</sup>	31.7489 kgm <sup>2</sup>
SHIPPING WEIGHTS in a crate	2833kg	2779kg
PACKING CRATE SIZE	194 x 105 x 154(cm)	194 x 105 x 154(cm)

	50 Hz				60 Hz			
TELEPHONE INTERFERENCE	THF<2%				TIF<50			
COOLING AIR	2.69 m <sup>3</sup> /sec 5700 cfm				3.45 m <sup>3</sup> /sec 7300 cfm			
VOLTAGE STAR	380/220	400/231	415/240	440/254	416/240	440/254	460/266	480/277
kVA BASE RATING FOR REACTANCE VALUES	1225	1260	1260	1235	1370	1500	1510	1525
X <sub>d</sub> DIR. AXIS SYNCHRONOUS	3.51	3.26	3.02	2.64	4.23	4.14	3.81	3.53
X' <sub>d</sub> DIR. AXIS TRANSIENT	0.21	0.20	0.18	0.16	0.26	0.25	0.23	0.22
X'' <sub>d</sub> DIR. AXIS SUBTRANSIENT	0.16	0.15	0.14	0.12	0.19	0.19	0.17	0.16
X <sub>q</sub> QUAD. AXIS REACTANCE	2.26	2.10	1.95	1.70	2.73	2.67	2.46	2.28
X'' <sub>q</sub> QUAD. AXIS SUBTRANSIENT	0.32	0.29	0.27	0.24	0.38	0.37	0.34	0.32
X <sub>L</sub> LEAKAGE REACTANCE	0.04	0.04	0.03	0.03	0.05	0.05	0.04	0.04
X <sub>2</sub> NEGATIVE SEQUENCE	0.22	0.21	0.19	0.17	0.27	0.26	0.24	0.23
X <sub>0</sub> ZERO SEQUENCE	0.03	0.03	0.02	0.02	0.03	0.03	0.03	0.03

REACTANCES ARE SATURATED

VALUES ARE PER UNIT AT RATING AND VOLTAGE INDICATED

T' <sub>d</sub> TRANSIENT TIME CONST.	0.13s
T'' <sub>d</sub> SUB-TRANSTIME CONST.	0.01s
T' <sub>do</sub> O.C. FIELD TIME CONST.	2.14s
T <sub>a</sub> ARMATURE TIME CONST.	0.02s
SHORT CIRCUIT RATIO	1/X <sub>d</sub>

50  
Hz

PI734A  
Winding 312

STAMFORD

THREE PHASE EFFICIENCY CURVES

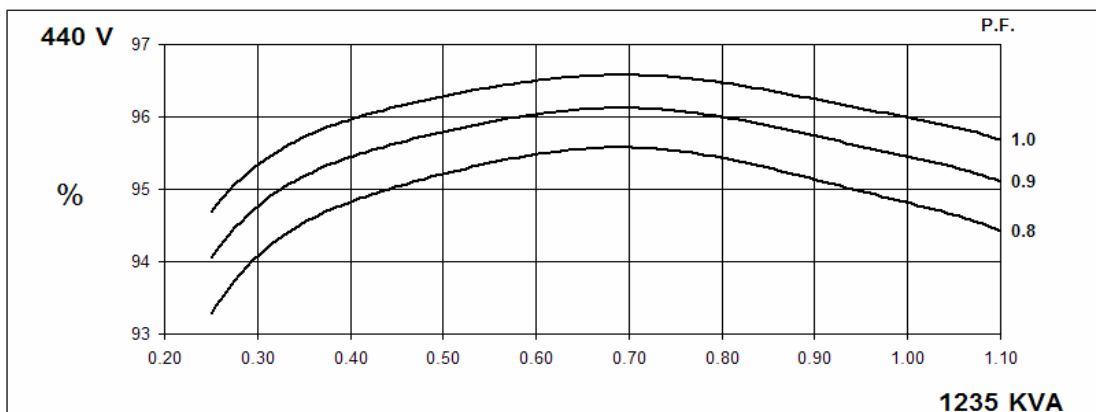
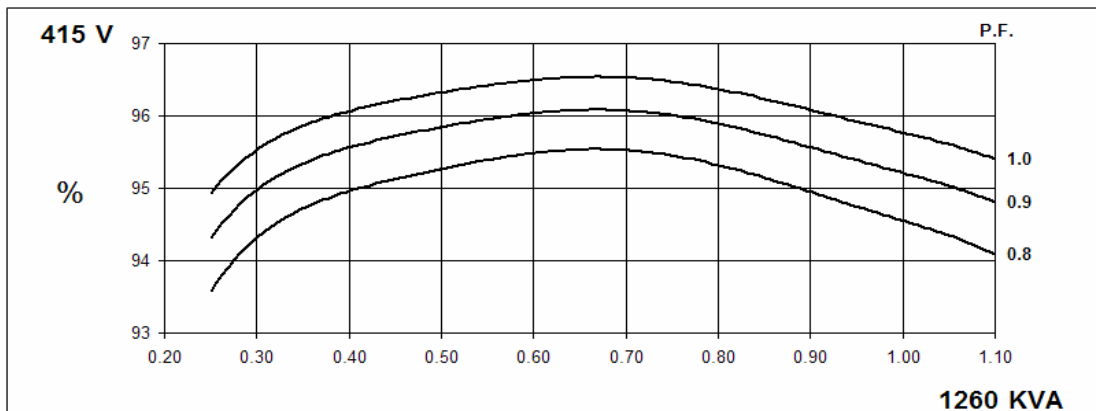
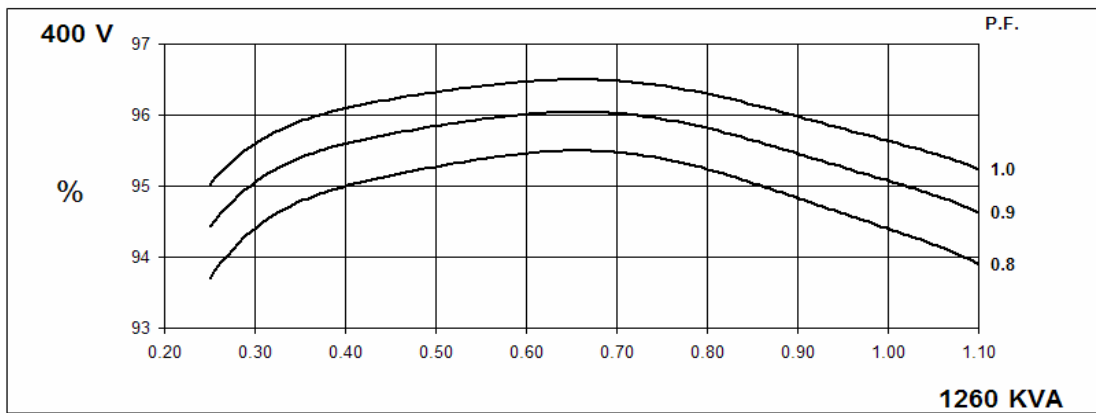
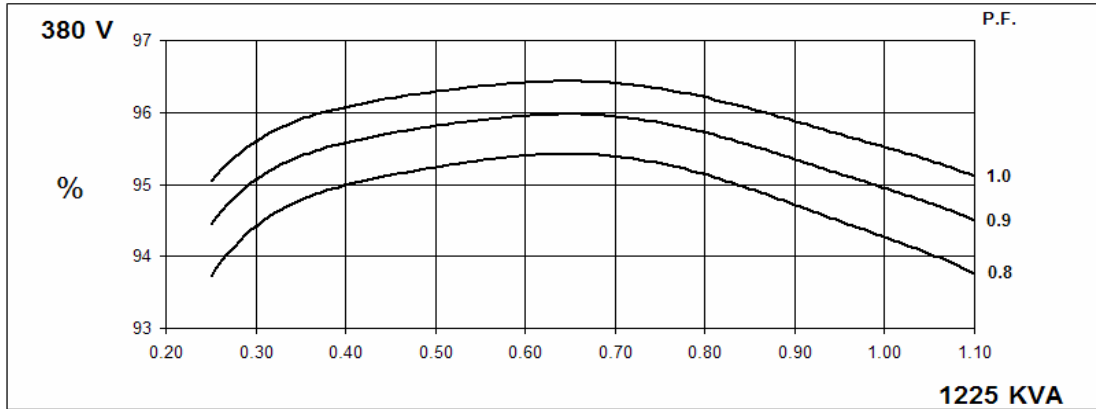

60  
Hz

PI734A  
Winding 312

STAMFORD

THREE PHASE EFFICIENCY CURVES

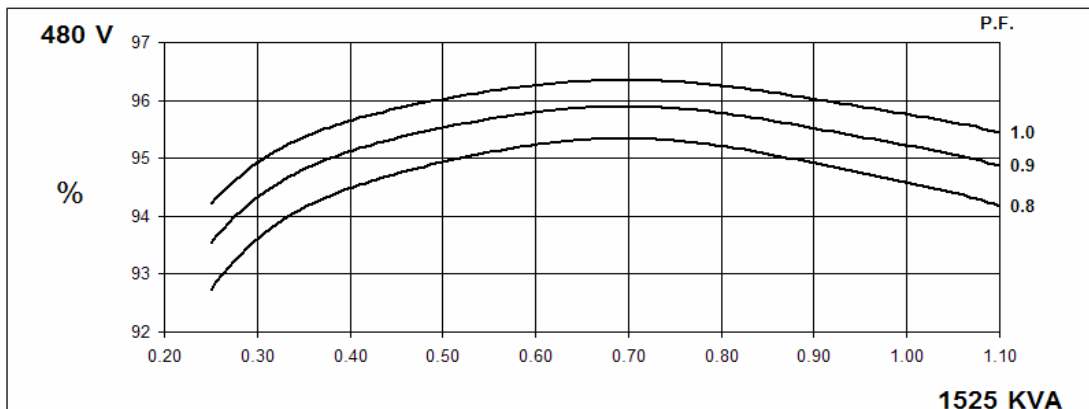
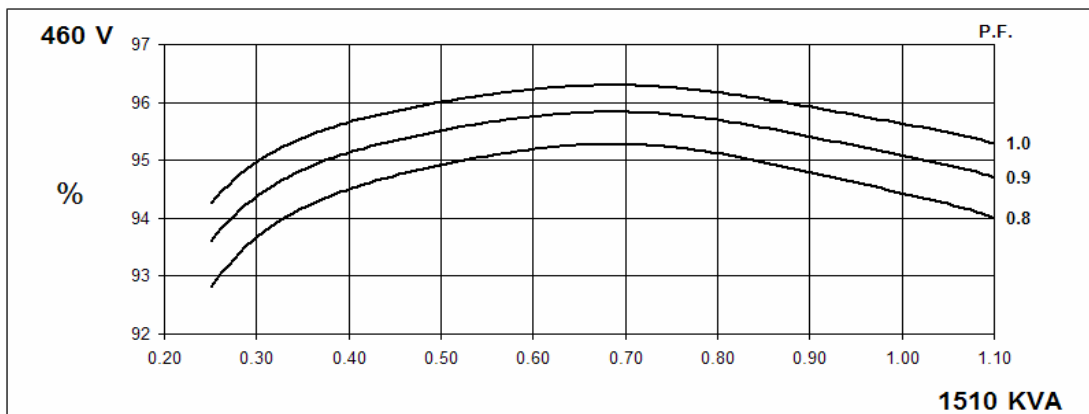
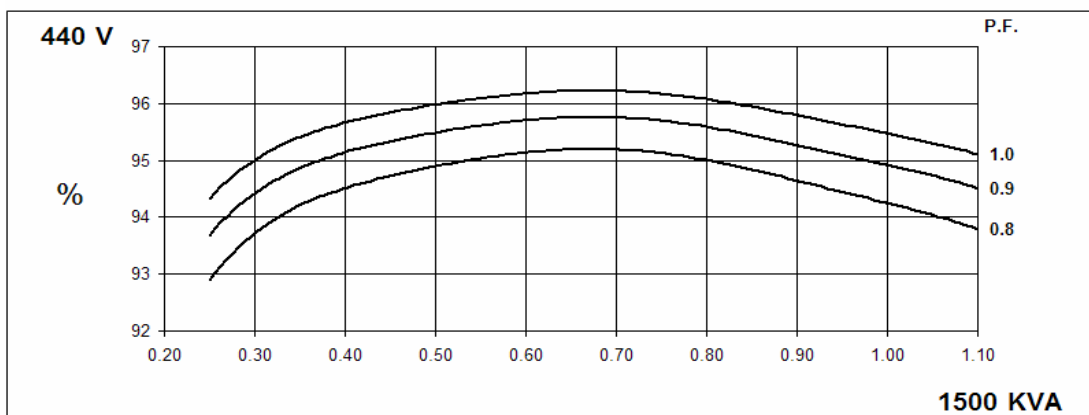
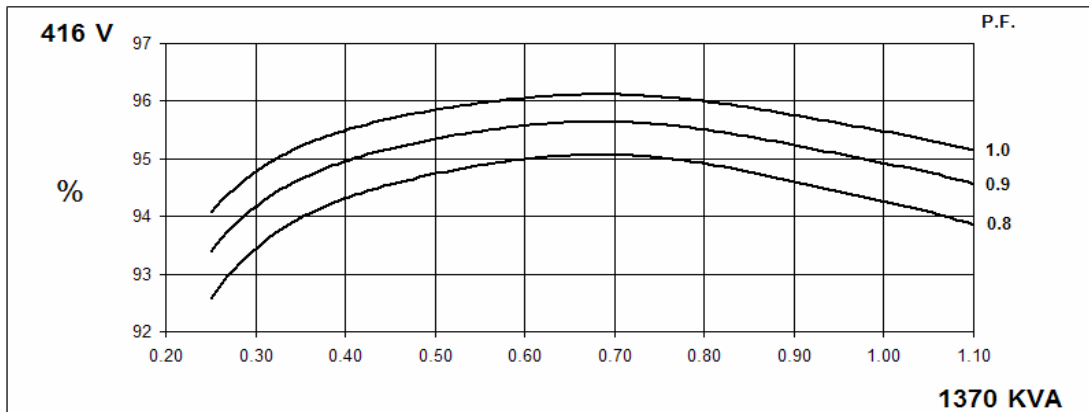

PI734A  
Winding 312

**STAMFORD**

**Locked Rotor Motor Starting Curve**

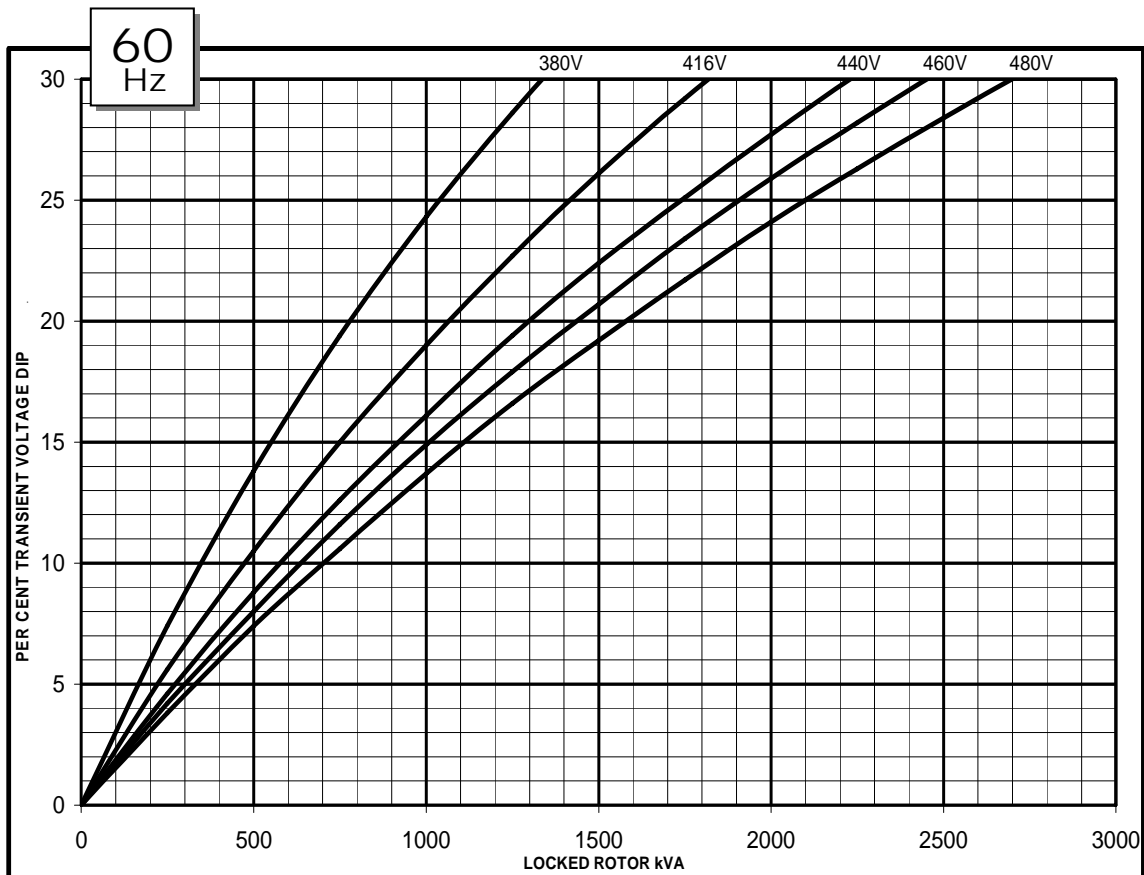
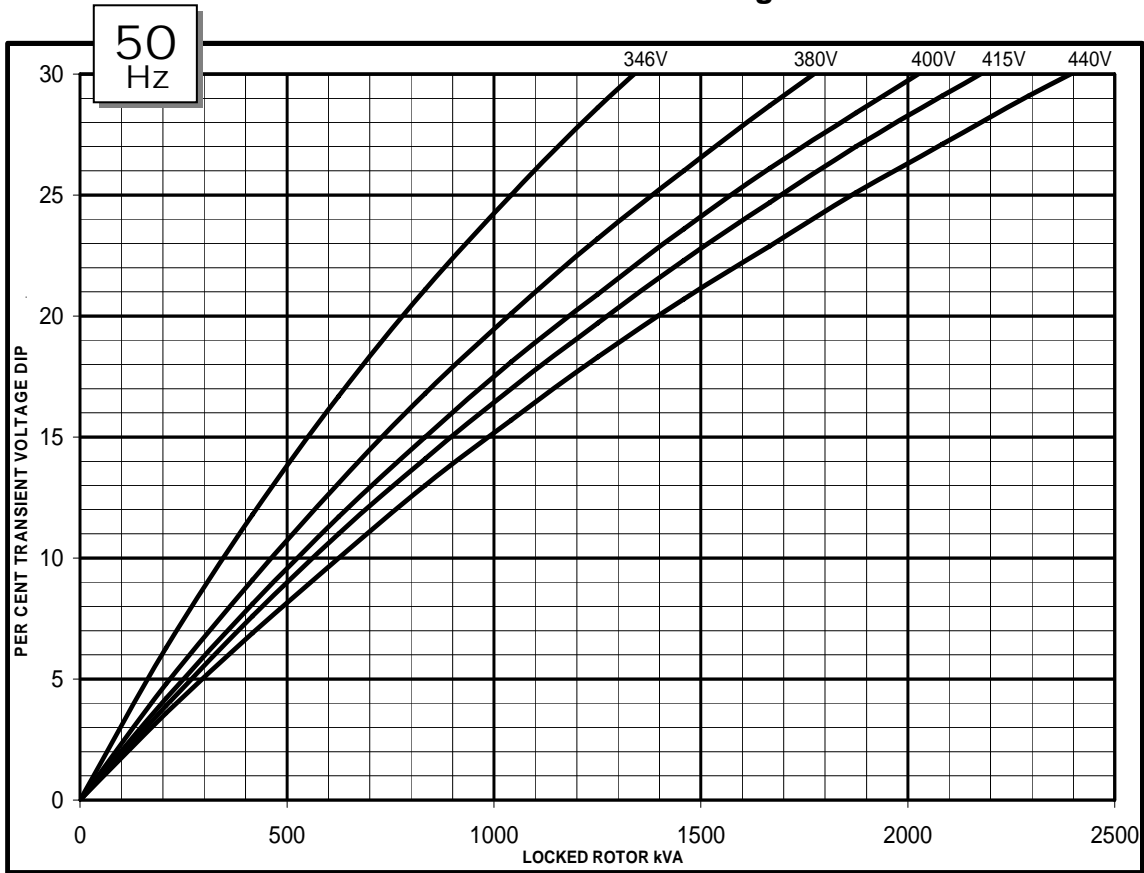

**Three-phase Short Circuit Decrement Curve. No-load Excitation at Rated Speed  
Based on star (wye) connection.**

50  
Hz

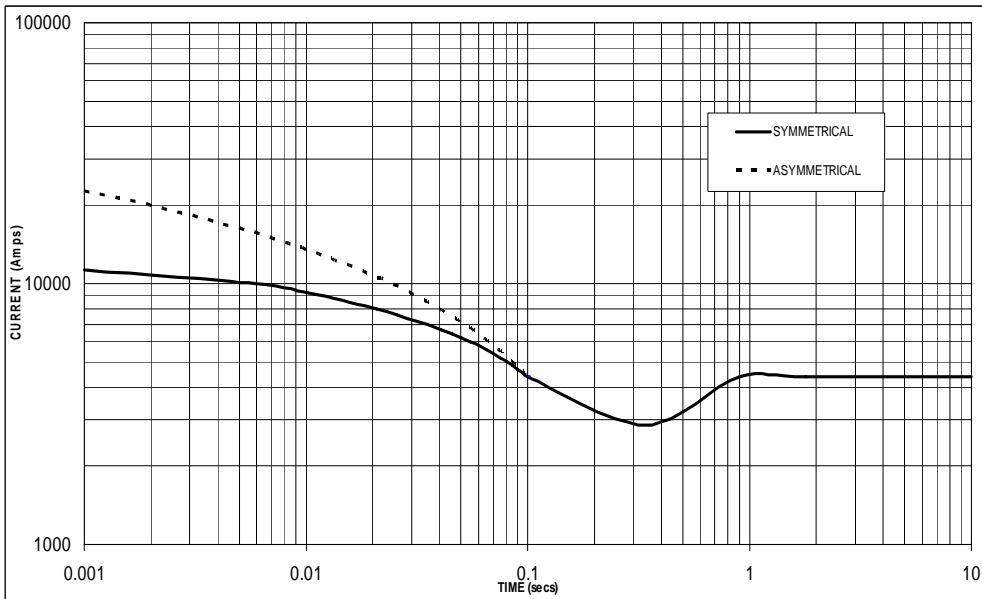

Sustained Short Circuit = 4,400 Amps

60  
Hz

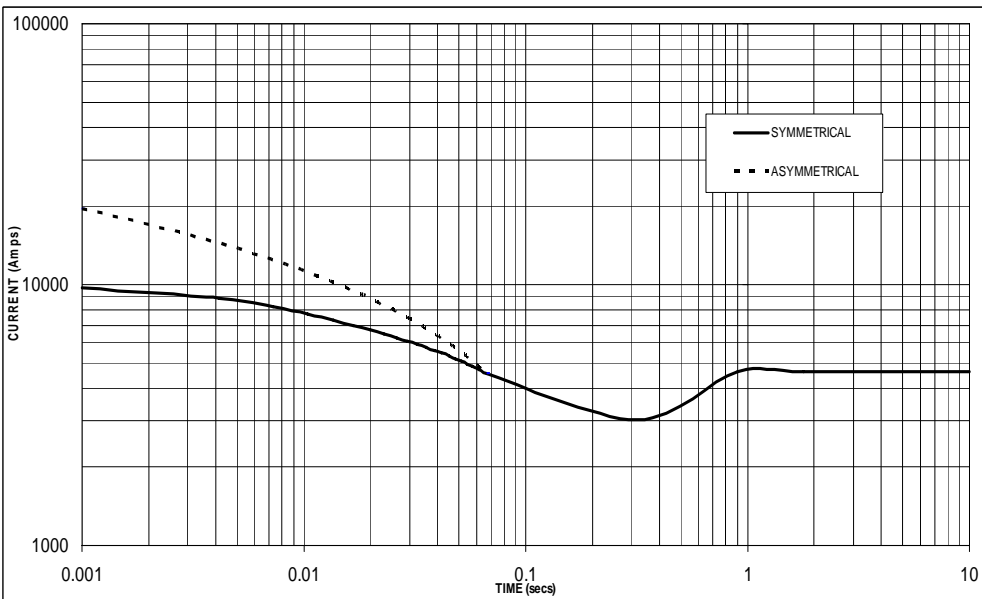

Sustained Short Circuit = 4,650 Amps

**Note 1**

The following multiplication factors should be used to adjust the values from curve between time 0.001 seconds and the minimum current point in respect of nominal operating voltage :

50Hz		60Hz	
Voltage	Factor	Voltage	Factor
380v	x 1.00	416v	x 1.00
400v	x 1.05	440v	x 1.06
415v	x 1.09	460v	x 1.10
440v	x 1.16	480v	x 1.15

The sustained current value is constant irrespective of voltage level

**Note 2**

The following multiplication factor should be used to convert the values calculated in accordance with NOTE 1 to those applicable to the various types of short circuit :

	3-phase	2-phase L-L	1-phase L-N
Instantaneous	x 1.00	x 0.87	x 1.30
Minimum	x 1.00	x 1.80	x 3.20
Sustained	x 1.00	x 1.50	x 2.50
Max. sustained duration	10 sec.	5 sec.	2 sec.

All other times are unchanged

**Note 3**

Curves are drawn for Star (Wye) connected machines.

**PI734A**  
**Winding 312 / 0.8 Power Factor**

**RATINGS**

Class - Temp Rise		Cont. F - 105/40°C				Cont. H - 125/40°C				Standby - 150/40°C				Standby - 163/27°C			
<b>50Hz</b>	Star (V)	380	400	415	440	380	400	415	440	380	400	415	440	380	400	415	440
	kVA	1140	1175	1175	1150	1225	1260	1260	1235	1275	1315	1315	1290	1310	1350	1350	1325
	kW	912	940	940	920	980	1008	1008	988	1020	1052	1052	1032	1048	1080	1080	1060
	Efficiency (%)	94.5	94.6	94.8	95.0	94.3	94.4	94.6	94.8	94.1	94.2	94.4	94.7	94.0	94.1	94.3	94.6
	kW Input	965	994	992	968	1039	1068	1066	1042	1084	1117	1114	1090	1115	1148	1145	1121

<b>60Hz</b>	Star (V)	416	440	460	480	416	440	460	480	416	440	460	480	416	440	460	480
	kVA	1275	1395	1405	1415	1370	1500	1510	1525	1425	1560	1570	1585	1465	1605	1615	1630
	kW	1020	1116	1124	1132	1096	1200	1208	1220	1140	1248	1256	1268	1172	1284	1292	1304
	Efficiency (%)	94.5	94.5	94.6	94.8	94.3	94.2	94.4	94.6	94.1	94.1	94.3	94.5	94.0	94.0	94.2	94.4
	kW Input	1079	1181	1188	1194	1162	1274	1280	1290	1211	1326	1332	1342	1247	1366	1372	1381

**DIMENSIONS**

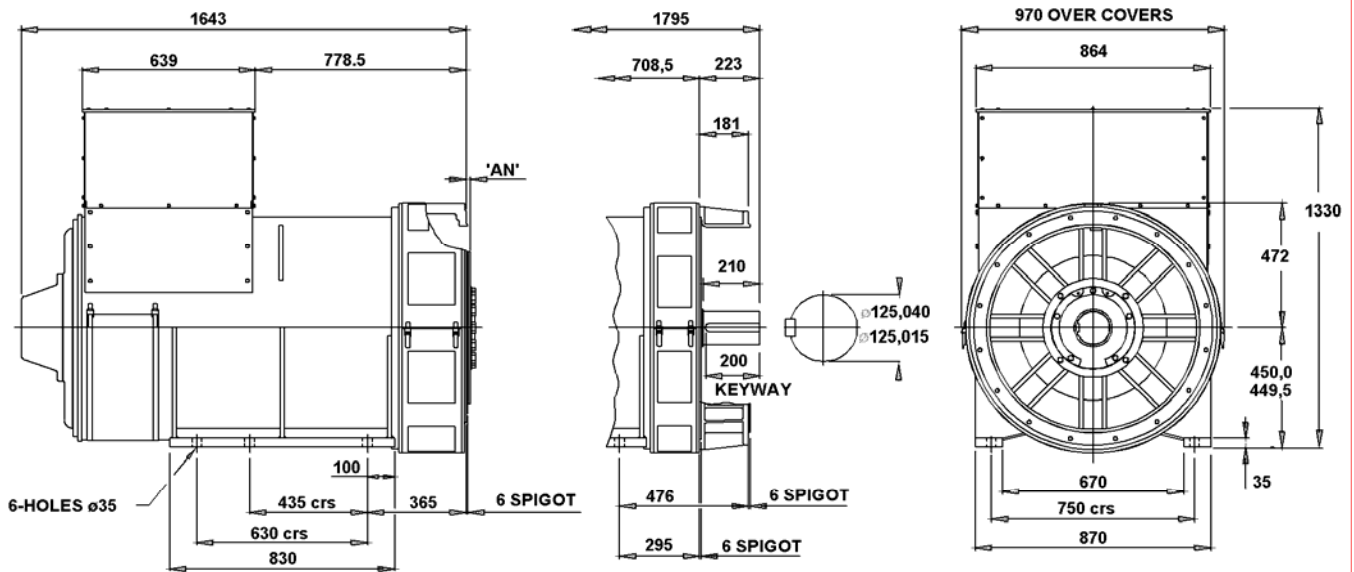

COUPLING DISC	'AN'
S.A.E No 18	15,7
S.A.E No 21	0
S.A.E No 24	0

1-BRG ADAPTORS
S.A.E No 0
S.A.E No 00

2-BRG ADAPTORS
S.A.E No 0
S.A.E No 00

# Diesel Generator set KTA38 series engine



> **Specification sheet**  
900-1250 kVA 50Hz

**Our energy working for you.™**



## Description

This Cummins® Power Generation commercial generator set is a fully integrated power generation system, providing optimum performance, reliability, and versatility for stationary standby, prime power, and continuous duty applications.



This generator set is available with CE certification.

**2000/14/EC**

All enclosed products are designed to meet or exceed EU noise legislation 2000/14/EC step 2006.

**ISO8528**

This generator set has been designed to comply with ISO8528 regulation.



This generator set is designed in facilities certified to ISO9001 and manufactured in facilities certified to ISO9001 or ISO9002.

## Features

**Cummins® Heavy-Duty Engine** - Rugged 4-cycle industrial diesel delivers reliable power, low emissions and fast response to load changes.

**Permanent Magnet Generator (PMG)** - Offers enhanced motor starting and fault clearing short circuit capability.

**Alternator** - Several alternator sizes offer selectable motor starting capability with low reactance 2/3 pitch windings; low waveform distortion with non-linear loads, fault clearing short-circuits capability, and class H insulation.

**Control system** - Standard PowerCommand® electronic control provides total system integration including remote start/stop, precise frequency and voltage regulation, alarm and status message display, AmpSentry™ protection, output metering, auto-shutdown.

**Cooling System** - Standard integral set-mounted radiator system, designed and tested for rated ambient temperatures, simplifies facility design requirements for rejected heat.

**Warranty and Service** – Backed by a comprehensive warranty and worldwide distributor network.

Genest Model	Standby Rating		Prime Rating		Engine Model	Alternators Model	Genset Controller
	50Hz/kVA	50Hz /kWe	50Hz/kVA	50Hz/kWe			
C1000 D5	1062	850	1012	810	KTA38-G5	HCI634J	PC3.3
C1100 D5B	1132	906	1029	823	KTA38-G5	HCI634K	PC3.3
C1250 D5A	1250	1000	1125	900	KTA38-G9	PI734A	PC3.3

**Our energy working for you.™**

[www.cummins.power.com](http://www.cummins.power.com)

©2016 | Cummins Power Generation Inc. | All rights reserved | Specifications subject to change without notice | Cummins Power Generation and Cummins are registered trademarks of Cummins Inc. PowerCommand, AmpSentry, InPower and "Our energy working for you." are trademarks of Cummins Power Generation. Other company, product or service names may be trademarks or service marks of others. EA\_S\_CC\_23\_EN V2 (2016/03).



## Generator Set Specifications

Governor Regulation Class	ISO8528
Voltage Regulation, No Load to Full Load	1%
Random Voltage Variation	1%
Frequency Regulation	Isochronous
Random Frequency Variation	±0.25%
EMC Compatibility	EN61000-6-4 / EN61000-6-2
Radio Frequency Emission Compliance	IEC 801.2 through IEC 801.5 MIL STD 461C Part 9

## Engine Specifications

Design	4 cycle, in line, turbo Charged and after-cooled
Bore	159mm (6.25in.)
Stroke	159mm (6.25in.)
Displacement	38 liter (2300 in <sup>3</sup> )
Cylinder Block	Twelve-cylinder vee formation, direct injection, four-cycle diesel engine
Battery Capacity	890 amps at ambient temperature 32 <sup>o</sup> F (0°C)
Battery Charging Alternator	55 amps
Starting Voltage	24-volt, negative ground
Fuel System	Direct injection
Fuel Filter	Dual spin on paper element fuel filters with standard water separator.
Air Cleaner Type	Dry replaceable element
Lube Oil Filter Type(s)	Spin-on paper element full flow and bypass lube oil filters.
Standard Cooling System	104°F (40°C) ambient radiator

Design	Brushless, 4 pole, drip proof revolving field
Stator	2/3 pitch
Rotor	Direct coupled by flexible disc
Insulation System	Class H
Standard Temperature Rise	150°C Standby
Exciter Type	PMG (Permanent Magnet Generator)
Phase Rotation	A (U), B (V), C (W)
Alternator Cooling	Direct drive centrifugal blower fan
AC Waveform Total Harmonic Distortion	No load < 1.5%. Non distorting balanced linear load < 5%
Telephone Influence Factor (TIF)	TIF <50 Per NEMA MG1-22.43
Telephone Harmonic Factor (THF)	THF <3%

## Alternator Specifications

### Available Voltages

#### 50Hz Line – Neutral / Line – Line

• 110/190	• 220/380
• 115/200	• 230/400
• 120/208	• 240/416
• 127/220	• 255/440

\* Derate may be applicable at this voltage. Please consult the factory for details.

## Generator Set Options

### Engine

- Heavy Duty air filter
- Water jacket heater 220/240 v

### Alternator

- Alternator heater

### Warranty

- 5 years for Standby application
- 2 years for Prime application

### Battery

- Battery
- Battery Charger

### Circuit Breaker

- 3 pole Main Circuit Breaker

### Silencer

- 25 dB industrial - delivered loose

\*Note: Some options may not be available on all models – consult factory for availability.

Our energy working for you.™

[www.cummins-power.com](http://www.cummins-power.com)

©2016 | Cummins Power Generation Inc. | All rights reserved | Specifications subject to change without notice | Cummins Power Generation and Cummins are registered trademarks of Cummins Inc. PowerCommand, AmpSentry, InPower and "Our energy working for you." are trademarks of Cummins Power Generation. Other company, product or service names may be trademarks or service marks of others.EA\_S\_CC\_23\_EN V2 (2016/03).



## PowerCommand®3.3 – Control System



### Control system

The PowerCommand® control system is an integrated microprocessor based generator set control system providing voltage regulation, engine protection, alternator protection, operator interface and isochronous governing.

**AmpSentry** – Includes integral AmpSentry protection, which provides a full range of alternator protection functions that are matched to the alternator provided.

**Power management** – Control function provides battery monitoring and testing features and smart starting control system.

**Advanced control methodology** – Three phase sensing, full wave rectified voltage regulation, with a PWM output for stable operation with all load types.

**Communications interface** – Control comes standard with PCCNet and Modbus interface.

**Regulation compliant** – Prototype tested: UL, CSA and CE compliant.

**Service** - InPower™ PC-based service tool available for detailed diagnostics, setup, data logging and fault simulation.

**Reliable design** – The control system is designed for reliable operation in harsh environment.

**Multi-language support**

### Operator panel features

**Operator panel features** – The operator panel, in addition to the alternator, displays the Utility/AC Bus data.

#### Operator/display functions

- 320 x 240 pixels graphic LED backlight LCD
- Auto, manual, start, stop, fault reset and lamp test/panel lamp switches
- Alpha-numeric display with pushbuttons
- LED lamps indicating genset running, remote start, not in auto, common shutdown, common warning, manual run mode, auto mode and stop

#### Paralleling control functions

- Digital frequency synchronization and voltage matching
- Isochronous kW and kvar load sharing controls
- Droop kW and kvar control
- Sync check
- Extended paralleling (Peak Shave/Base Load)
- Digital power transfer control (AMF) provides load transfer operation in open or closed transition or soft (ramping) transfer mode

#### Alternator data

- Line-to-neutral and line-to-line AC volts
- 3-phase AC current
- Frequency
- kW, kvar, power factor kVA (three phase and total)

#### Engine data

- DC voltage
- Engine speed
- Lube oil pressure and temperature
- Coolant temperature
- Comprehensive FAE data (where applicable)

#### Other data

- Genset model data
- Start attempts, starts, running hours, kW hours
- Load profile (operating hours at % load in 5% increments)
- Fault history
- Data logging and fault simulation (requires InPower)

### Standard control functions

#### Digital governing (optional)

- Integrated digital electronic isochronous governor
- Temperature dynamic governing

#### Digital voltage regulation

- Integrated digital electronic voltage regulator
- 3-phase, 4-wire line-to-line sensing
- Configurable torque matching

#### AmpSentry AC protection

- AmpSentry protective relay
- Over current and short circuit shutdown
- Over current warning
- Single and three phase fault regulation
- Over and under voltage shutdown
- Over and under frequency shutdown
- Overload warning with alarm contact
- Reverse power and reverse var shutdown
- Field overload

#### Engine protection

- Battery voltage monitoring, protection and testing
- Over speed shutdown
- Low oil pressure warning and shutdown
- High coolant temperature warning and shutdown
- Low coolant level warning or shutdown
- Low coolant temperature warning
- Fail to start (over crank) shutdown
- Fail to crank shutdown
- Cranking lockout
- Sensor failure indication
- Low fuel level warning or shutdown
- Fuel-in-rupture-basin warning or shutdown
- Full authority electronic engine protection

#### Control functions

- Time delay start and cool down
- Real time clock for fault and event time stamping
- Exerciser clock and time of day start/stop
- Data logging
- Cycle cranking
- Load shed
- Configurable inputs and outputs (4)
- Remote emergency stop

#### Options

- Auxiliary output relays (2) yes

Our energy working for you.™

[www.cummins-power.com](http://www.cummins-power.com)

©2016 | Cummins Power Generation Inc. | All rights reserved | Specifications subject to change without notice | Cummins Power Generation and Cummins are registered trademarks of Cummins Inc. PowerCommand, AmpSentry, InPower and "Our energy working for you." are trademarks of Cummins Power Generation. Other company, product or service names may be trademarks or service marks of others. EA\_S\_CC\_23\_EN V2 (2016/03).



## Ratings Definitions

### Emergency Standby Power (ESP):

Applicable for supplying power to varying electrical load for the duration of power interruption of a reliable utility source. Emergency Standby Power (ESP) is in accordance with ISO 8528. Fuel Stop power in accordance with ISO 3046, AS 2789, DIN 6271 and BS 5514.

### Limited-Time running Power (LTP):

Applicable for supplying power to a constant electrical load for limited hours. Limited Time Running Power (LTP) is in accordance with ISO 8528.

### Prime Power (PRP):

Applicable for supplying power to varying electrical load for unlimited hours. Prime Power (PRP) is in accordance with ISO 8528. Ten percent overload capability is available in accordance with ISO 3046, AS 2789, DIN 6271 and BS 5514.

**Base Load (Continuous) Power (COP):** Applicable for supplying power continuously to a constant electrical load for unlimited hours. Continuous Power (COP) in accordance with ISO 8528, ISO 3046, AS 2789, DIN 6271 and BS 5514.

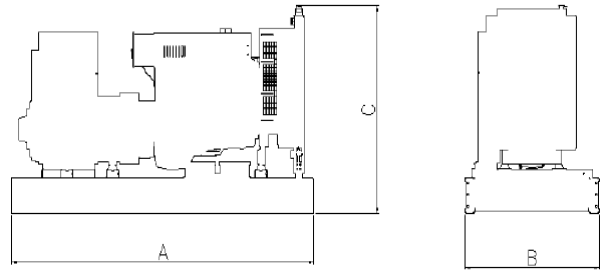

This outline drawing is to provide representative configuration details for Model series only.

See respective model data sheet for specific model outline drawing number.

Do not use for installation design.

Model	Dim "A" mm	Dim "B" mm	Dim "C" mm	Set weight* dry kg	Set weight* wet kg
C1000 D5	4374	1785	2229	7667	8057
C1100 D5	4374	1785	2229	7960	8350
C1250 D5A	4722	1785	2241	8179	8569

\*Note: Weights represent a set with standard features. See outline drawings for weights of other configurations.

### Cummins Power Generation

#### Europe, CIS, Middle East and Africa

Manston Park Columbus Ave  
Manston, Ramsgate  
Kent CT12 BF United Kingdom  
Phone 44 1843 255000  
Fax 44 1843 255902

#### Asia Pacific

10 Toh Guan Road #07-01  
TT International Tradepark  
Singapore 608838  
Phone 65 6417 2388  
Fax 65 6417 2399

#### East Asia

2 Rongchang East Street  
Beijing Economic-Technological  
Development Area  
Beijing 1000176 P.R China  
Phone 86 10 5902 3000  
Fax 86 10 5902 3199

Our energy working for you.™

[www.cummins power.com](http://www.cummins power.com)

©2016 | Cummins Power Generation Inc. | All rights reserved | Specifications subject to change without notice | Cummins Power Generation and Cummins are registered trademarks of Cummins Inc. PowerCommand, AmpSentry, InPower and "Our energy working for you." are trademarks of Cummins Power Generation. Other company, product or service names may be trademarks or service marks of others. EA\_S\_CC\_23\_EN V2 (2016/02).



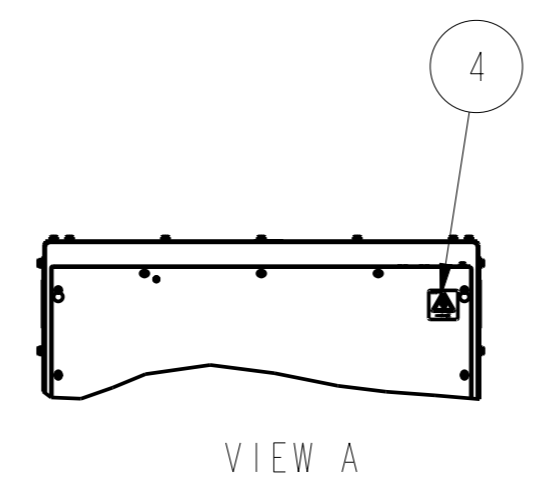
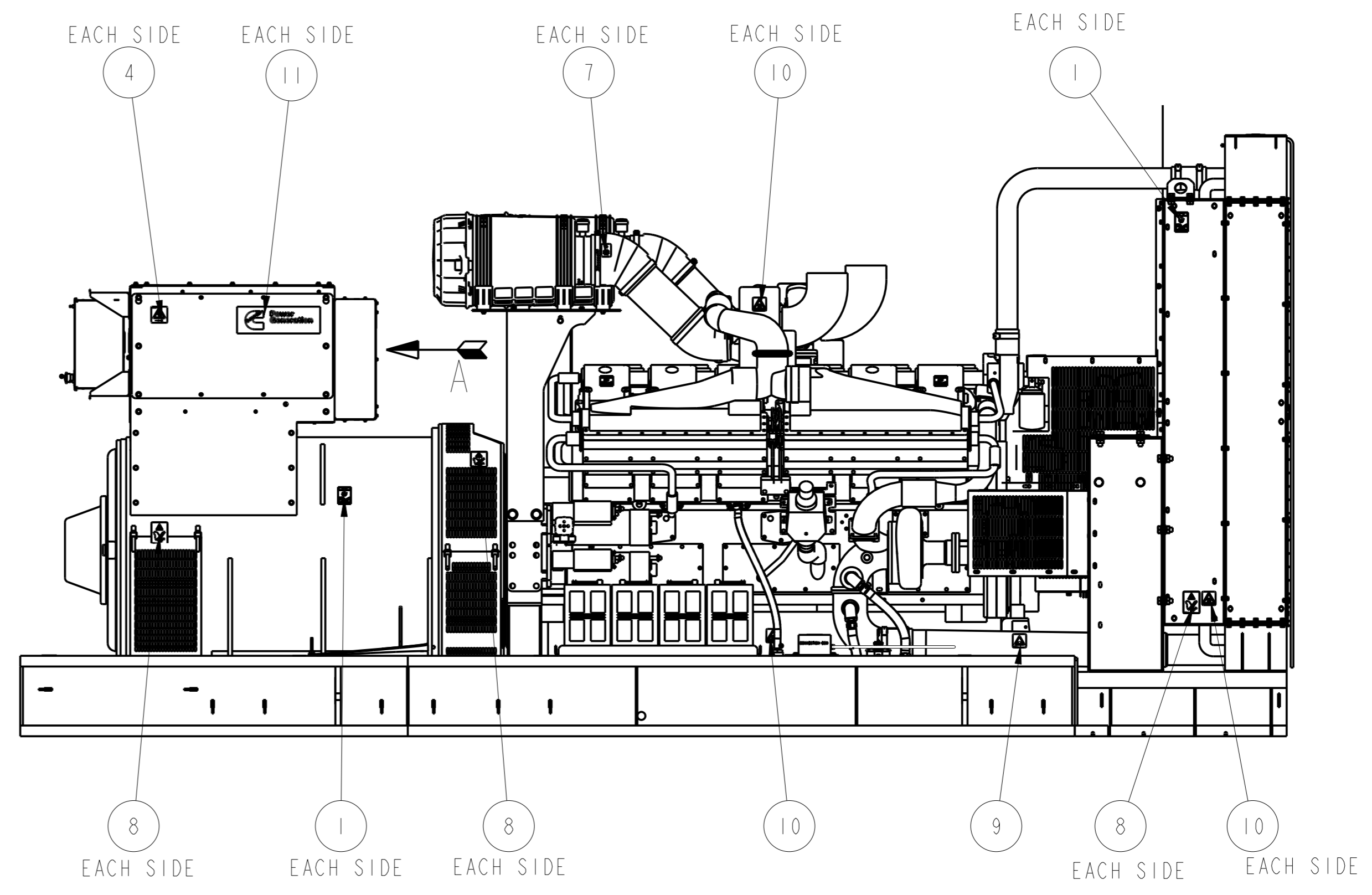
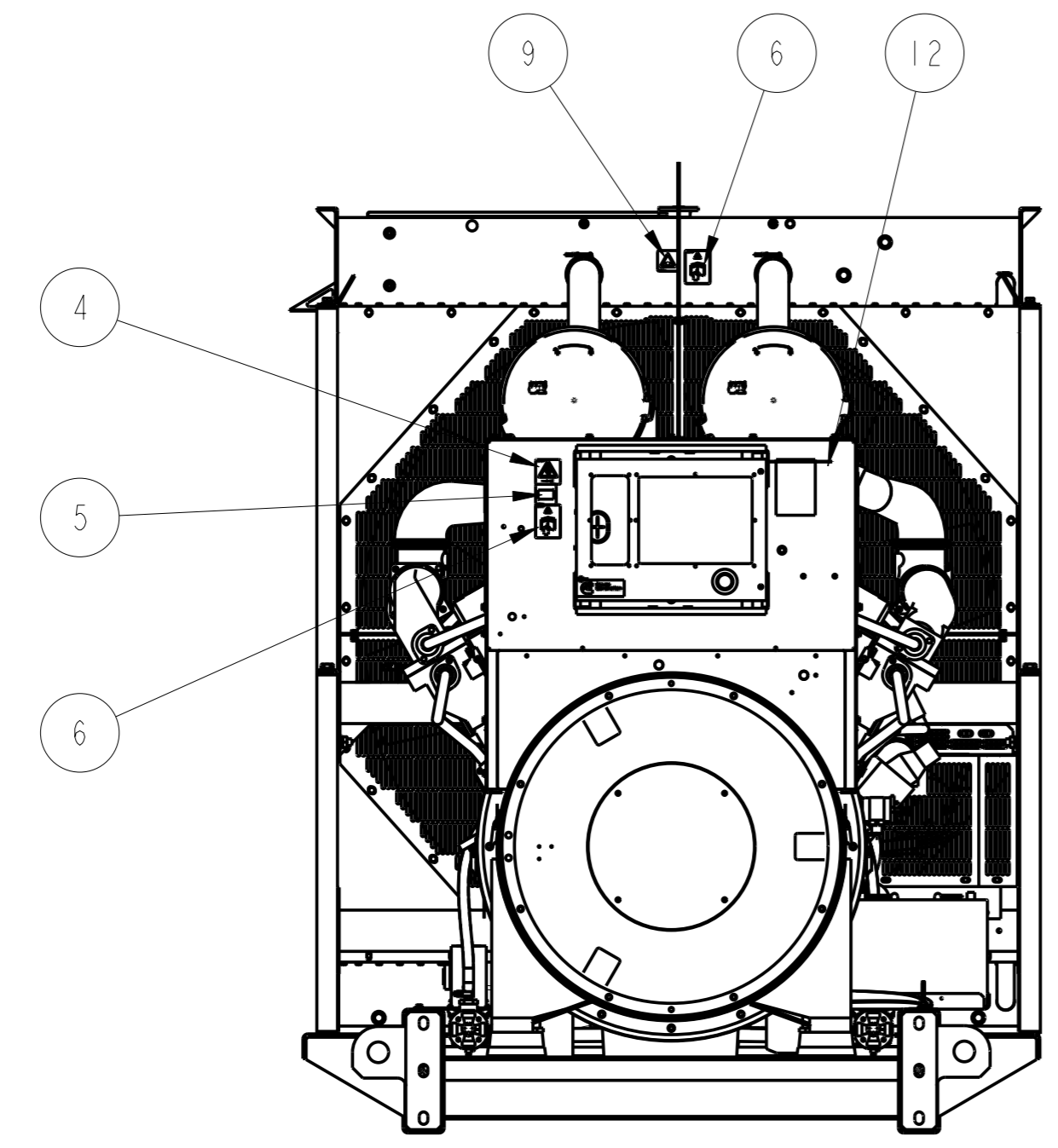
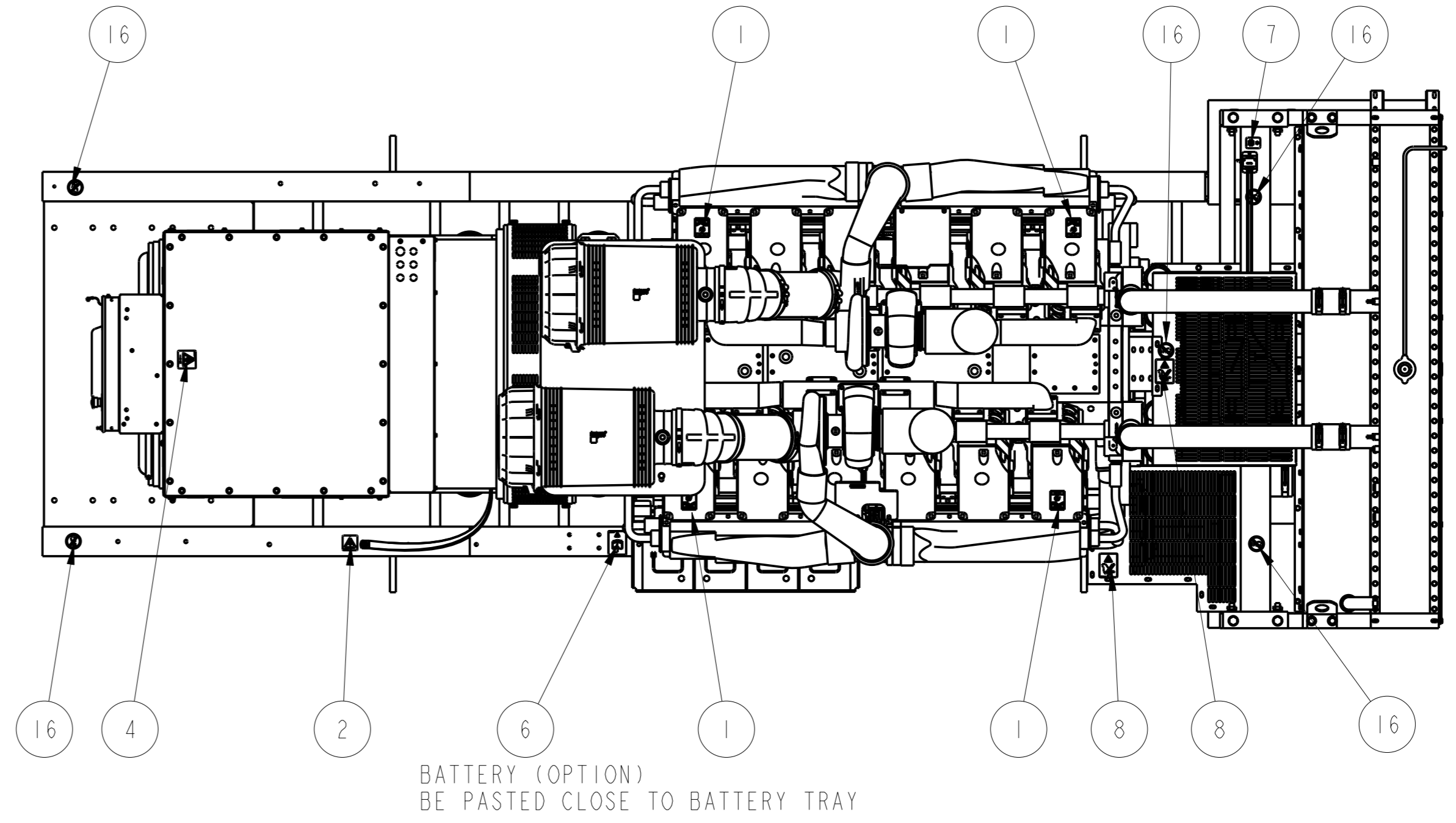
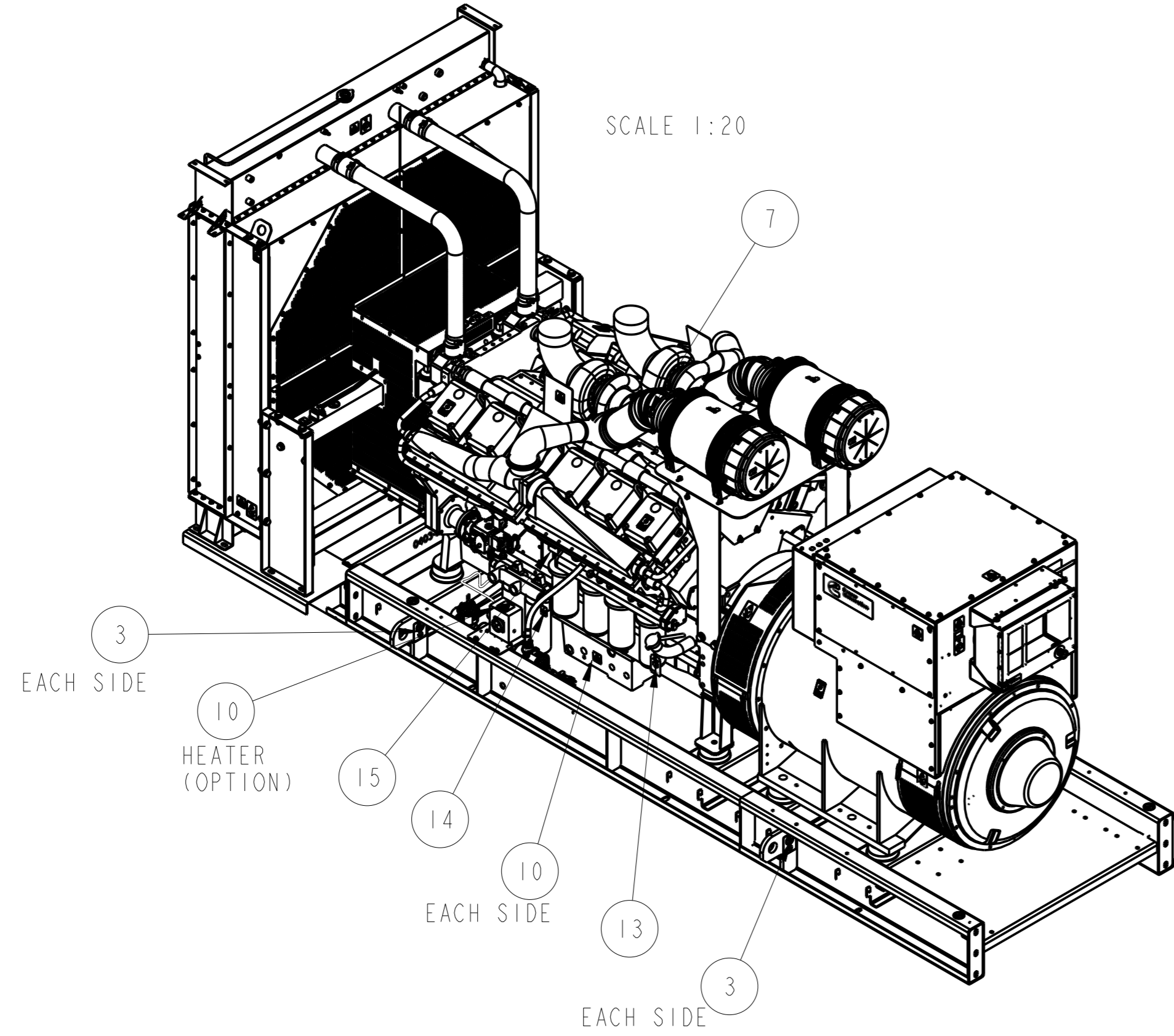

<b>DO NOT SCALE PRINT</b>	TOLERANCE UNLESS STATED ALL DIMENSIONS IN MM	SIM TO	DRAWN	ROSE ZHU	CUMMINS POWER GENERATION
	0.1M	COPIED FROM	CHECK	AARON WANG	
ANG TOL ± 1.0°	0.05 - 4.99 ± 0.15/0.20 5.00 - 9.99 ± 0.20/0.10 10.00 - 17.49 ± 0.25/0.15 17.50 - 24.99 ± 0.30/0.12	THIRD ANGLE PROJECTION	APPR	GERALD XIAO	TITLE
DRAWN TO SCALE OF 1:15	THIS DOCUMENT IS THE PROPERTY OF CUMMINS POWER GENERATION. IT CONTAINS PROPRIETARY AND CONFIDENTIAL INFORMATION WHICH MUST NOT BE REPRODUCED, COPIED OR DISCLOSED OTHER THAN EXPRESSLY AUTHORIZED BY CUMMINS POWER GENERATION OR ITS REPRESENTATIVE.	DATE	05MAY14	SITE CODE	INSTALLATION LABEL
	FOR INTERPRETATION OF DIMENSIONS AND TOLERANCING, SEE BS-1000	FIRST USED ON	C1250D5A	PGC	DWG NO
					A049U934
					SHEET 1 OF 1

**Part A049U934 A**

Description	Legacy Name	External Regulations	Application Status	Release Phase Code	Security Classification	Alternates
INSTALLATION,LABEL	A049U934	None	Production & Service	Production	Proprietary	

**Part Specifications :A049U934 A**

Name	Description	Legacy Name
A030B356	SPECIFICATION,MATERIAL	CES10903
A049U935	DRAWING,ENGINEERING	A049U935

**Engineering BOM: A049U934 A Level 1**

Name	Description	Legacy Name	Find Number	Reference Designator	Quantity	Unit of Measure
A004C703	LABEL,WARNING	0098-7895	1		8.0	Each
A004B819	LABEL,INFORMATION	0098-8097	2		1.0	Each
A004B852	LABEL,INFORMATION	0098-8101	3		4.0	Each
A019C149	LABEL,WARNING	0098-8104	4		5.0	Each
A004B289	LABEL,DANGER	0098-8099	5		1.0	Each
A004C833	LABEL,WARNING	0098-8100	6		3.0	Each
A004C031	LABEL,INSTRUCTION	0098-8733	7		2.0	Each
A004B104	LABEL,CAUTION	0098-8130	8		5.0	Each
A004C830	LABEL,WARNING	0098-8094	9		2.0	Each
A030F757	LABEL,WARNING	A030F757	10		4.0	Each
A024C224	LABEL,LOGO	0098-7902	11		1.0	Each
A007X479	NAMEPLATE,GENSET	0099-2589-02	12		1.0	Each
A004B954	LABEL,INFORMATION	0098-8105	13		1.0	Each
A004B951	LABEL,INFORMATION	0098-8102	14		1.0	Each
A004B952	LABEL,INFORMATION	0098-8103	15		1.0	Each
A030F080	LABEL,WARNING	A030F080	16		7.0	Each